



Job or Customer: .....

Engineer: .....

Contractor: .....

Submitted by: ..... Date .....

Approved by: ..... Date .....

Order No: ..... Date .....

Specification: .....

## introduction

IPEX's **Enfield®** electrofusion-joint system is the preferred solution for virtually all non return air plenum chemical waste applications. Pipe and fittings are made from flame retardant Polypropylene. **Enfield®** Pipe and fittings comply with ASTM F1412 Standard specification for Polyolefin pipe and fittings for corrosive waste drainage systems. Material used in the manufacturing of **Enfield®** pipe and fittings complies with the material requirements of ASTM D4101 Standard Specification for polypropylene for Injection and Extrusion materials. All pipe and fittings are listed to NSF 14 standard and IAPMO.

### < STANDARDS >



ASTM F1412  
ASTM D 4101  
ASTM D 635  
ASTM D 311



NSF 14



File No:  
1103, 3455

### ADDITIONAL CORROSIVE WASTE PRODUCTS

#### FLOWAY™

ACID RESISTANT FLOOR DRAINS

#### NEUTRATANK®

NEUTRALIZATION TANKS

#### PLENUMLINE™

FR-PVDF MECHANICAL JOINT ACID WASTE SYSTEM

#### LABLINE®

MECHANICAL JOINT ACID WASTE SYSTEM

#### Encase™

PP Double Containment System

## pipe and fitting availability

1-1/2" - 12" Pipe (10' or 20', FRPP or NFRPP, Sch. 40 or Sch.80)	1-1/2"- 12" 45 Deg Wye and Reducing WYES FRPP
1-1/2" - 12" Couplings / CAPS, FRPP/ NFRPP	1-1/2" - 4" Glass Adapters, No Hub Adapters, Adapters FRPP
1-1/2" - 6" Cleanout FRPP	1-1/2" Universal Traps FRPP
1-1/2"- 6" 90°. Sweep , 90°. Sweep SOC. x SPIGOT FRPP	1-1/2" 90 Deg. Sweep, Loose Nut x Socket FRP
1-1/2"- 8" Repair Couplings, FRPP/ NFRPP	1-1/2" Loose Nut x FPT/ Socket, Adapters FRPP
1-1/2"- 12" 1/4 Bend FRPP	1-1/2" - 6" "P" Trap FRPP
1-1/2"- 12" 1/8 Bend FRPP	1-1/2" - 12" Reducing Bushings FRPP
8"- 12" ANSI 150 Bolt pattern blind flanges FRPP	1-1/2" - 6" Reducingcombination Wyes and 1/8 End FRPP
1-1/2"- 6" 1/8 Bend SOC. X SPIGOT FRPP	1-1/2" - 2" 1/4 Bend SOC. x SPIGOT FRPP
1-1/2" - 4" Male Adaptor FRPP	1-1/2" - 2" Female Adaptor FRPP
1-1/2"- 12" Reducing / Sanitary Tees, Reducing / Double Sanitary Tees FRPP	1-1/2" - 12" ANSI 150 Bolt Pattern Flanges FRPP
1-1/2"- 2" True Wye FRPP	1-1/2" - 4" Reducing True Wye FRPP
1-1/2"- 12" Combination Wyes and 1/8 Bend FRPP	1-1/2" - 12" Reducing Double 45 Wyes FRPP

## Installation Procedures

### Points to Remember

For installation in cold weather, refer to the 'Cold Weather Fusion' procedure described later in this section. Before making the Enfield joint, it is important to check with an RMS meter, that the power source is providing between 104 and 126 volts @ 45 to 65 cycles with 16-amp capacity. The Enfusion machine provides for normal power variations, however generators should be checked to assure the correct output is being provided.

### Procedure:

1. Using a tube cutter with a wheel designed for plastic (saw and miter box can also be used as an alternative), cut the **pipe square** making sure to remove all burrs and loose material. **Do not chamfer.**
2. Using 60-grit emery cloth, prepare the end of the pipe by removing dirt and oil (important to obtain a good bonding) and roughing up an area equal to 1.5 times the fitting's socket depth. Clean the roughed up area with ethyl or isopropyl alcohol to ensure complete removal of grease and residue. **Once treated do not handle this area of the pipe or allow it to get dirty.**
3. Completely unwind all cables from the Enfusion machine's frame before use.
4. Insert the pipe all the way to the stop at the bottom of the socket. If the pipe does not bottom against the pipe stop it may create excessive purge or leak paths.
5. Decide whether single or multiple joints are being made. In case of multiple joints consult the "Multiple Joints Fusion" table that follows for cable connections and maximum allowable number of simultaneous joints.
6. Loosely fit IPEX-supplied clamp(s) only over the hub(s) of the socket(s) to be fused.
7. Tighten the clamp(s) until it is not possible to rotate the pipe inside the fitting. A tight clamp is essential to the quality of the fusion cycle. quality of the joint. It should not be possible.
8. Turn the Enfusion machine on and observe the copyright message being displayed as the machine runs a self- diagnostic test.
9. Following the "CONNECT OUTPUT LEAD" instruction on the display, connect the output leads (Figure 2). If required, connect link cable for multiple fusions.

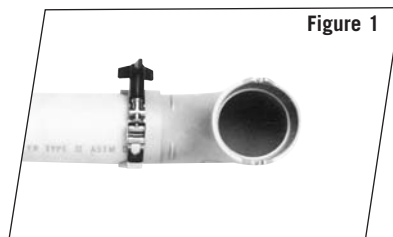

Figure 1

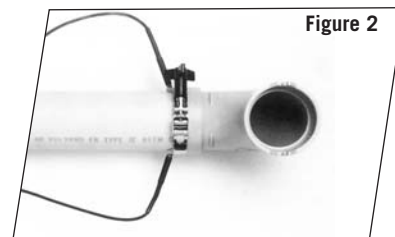

Figure 2

**Note:** Clamp position must be flush with the outer edge of the socket

## Installation Procedures

10. Following the "SELECT PIPE SIZE" instructions on the display, select the size of the joint being fused by using the "SELECT" button (Figure 3).



Figure 3



Figure 4

This will automatically set the fusion time (Figure 4).

11. Once the correct size is displayed, press the START button. Temperature and welding time will be displayed. Time will count down to zero.
12. Upon completion of the fusion cycle an audible alarm will sound and the message "DISCONNECT INPUT LEAD" will be displayed.
13. A 30 second rest period must be observed to allow the joint(s) to cool before disconnecting the leads. The Enfusion machine will automatically reset, ready for the next operation.
14. Allow five additional minutes before removing the clamps so that the joint can sufficiently cool and properly cure (Figure 5).

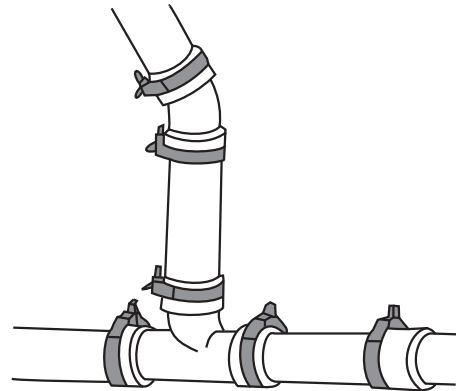

## Cold Weather Fusion

Whenever possible pipe and fittings should be stored indoors. It is always preferable to perform pipe preparation and welding in a protected environment. However, should that not be possible, during cold weather (particularly at freezing or below) it is recommended that both pipe and fittings be stored in similar ambient temperature and conditions.

In addition, when the actual welding takes place in freezing or sub-freezing environments, this cold weather pre-fusion procedure must be followed.

1. Follow steps 1 through 9 of Standard Enfield Electrofusion Installation.
2. When the "SELECT PIPE SIZE" prompt appears on the screen keep pushing the select button until all pipe sizes have been displayed.
3. Next will appear the first flash cycle: 1 1/2" to 2".
4. If the fitting(s) being welded is within this flash range, press START.
5. If the fitting(s) being welded is not included in this flash range, press the SELECT button one more time to display the second flash cycle: 3" through 12".
6. Press START.
7. Upon completion of the flash cycle, the display will show the "DISCONNECT INPUT LEAD" message. **Do not disconnect the leads.**
8. Tighten clamps if necessary (see notes below).
9. Allow the joints to cool for 5 minutes before beginning the fusion cycle.
10. After 5 minutes, continue with steps 10 through 14 of the Standard Enfield Electrofusion Installation procedure.

### NOTES

Screen the joints being fused from the wind in very cold conditions to prevent heat loss.

Particular care must be taken to adequately tighten the clamps during extremely cold weather because of increased stiffness of the materials. One or two additional turns of the tightening screw might be required, above and beyond what is commonly sufficient in fair weather conditions. This is particularly true when welding large diameters.

The additional tightening of the clamps, designed to eliminate any gap between the pipe and the fitting, should be performed towards the end of the flash cycle. However, care must be taken not to overtighten to avoid distorting or crushing the fitting joint.

Marking of the pipe (indicating socket depth) is also recommended to assure that the pipe remains fully seated in the socket during the fusion cycle.

## Testing Procedures



### WARNING

- **NEVER** use compressed air or gas in Enfield or Labline pipes, fittings, or accessories.
- **NEVER** test Enfield or Labline systems with compressed air or gas, or air-over-water boosters.
- **ONLY** use Enfield or Labline systems for water and approved chemicals.

Use of compressed air or gas in PP pipe and fittings can result in explosive failures and cause severe injury or death.



### Hydrostatic Testing Procedures

The purpose of a site pressure test is to establish that all joints have been correctly made.

Hydro test in accordance with local plumbing code or with authority having jurisdiction or with a maximum of 10 ft of head pressure. After making the first 20 or 30 joints, it is recommended that a test be applied to ensure that the joint-making technique is satisfactory. If a leak is discovered, follow the appropriate procedure below.

Hydrostatic testing of the joints can be performed 10 minutes after the final joint has been completed. The low pressure testing procedure detailed below should be strictly followed.

1. Fully inspect the installed piping for evidence of mechanical abuse and suspect joints.
2. Split the system into convenient test sections, not exceeding 1,000 feet. The piping should be capped off with an expandable plug at the end of the pipe section to be tested.
3. Prior to starting the test in below grade applications, straight lengths of pipe should be backfilled between fittings that are tested.
4. Slowly fill the pipe section with water, taking care to evaluate all trapped air in the process. Use air release valves in any high spots in the system. Do not pressurize at this stage.
5. Leave the pipe for at least one hour to allow an equilibrium temperature to be achieved.
6. Visually check the system for leaks.
7. Pressurize the system to a suggested maximum of 10 feet of head by means of a standard 10' standing water test using a 10' vertical riser, or a low-pressure hand pump.

## *Hydrostatic Testing Procedures*

8. Leave the line at 10 feet of head for a period of 2 hours, during which time the water level should not change (standing water test), nor should the pressure gauge reading change (hand pump test).
9. If there is a significant drop in pressure, or extended times are required to achieve the desired pressure, either joint leakage has occurred or air is still entrapped in the line. In this event inspect for joint leaks. If none are found, check for entrapped air – these air pockets must be removed prior to continuing the test.
10. If joints are found to be leaking, the system must be fully drained and the joints repaired. Dry, or marginal Enfield joints can be simply re-fused by following steps 5 through 14 in the Standard Enfield Electrofusion Installation procedure.
  - To remove moisture from the joint, use the flash cycle for the appropriate fitting size.
  - Wait 5 minutes to allow the joint to cool.
  - Now re-fuse using the correct Enfusion machine settings for the size of pipe being joined following steps 5-14 of the Standard Enfield Electrofusion Installation procedure.
  - Should any of the re-welded fitting(s) fail the second hydro-test, the leaking joint(s) can be back-welded with a hot-air gun and welding rod. Should the backwelded joint(s) fail a third hydro-test, they will need to be cut out of the system and substituted with new fittings.
  - If a joint has to be cut out and replaced, the procedure for pipe modification detailed in this manual should be strictly followed.
11. Repeat the 10 feet head test after repairing any leaking joints, following the procedure described above.

## Material Properties

Properties	Materials	
	Valve	Standards
Specific Gravity	0.94	D1505
Tensile Yield Strength @ 2"/Min.	4400 psi	D638
Flexural Modulus	215,000 psi	D790
Hardness, Rockwell R	100	D1706
Izod Impact, Notched	1.0 ft. lbs/in.	D256
Coefficient of Linear Expansion	$6 \times 10^{-5}$ in/in/F	D696
Heat Deflection Temperature @ 66 psi load	220 – 240°F	D648
Heat Deflection Temperature @ 264 psi load	195°F	D648
Water Absorption. 24 hrs.	0.01%	D570
Time of Burning (sec.)	< 5	D635
Extent of Burning (mm)	< 5	
Burning Class	V2	UL94
Maximum Smoke Density	62.0	D2843
Smoke Density Rating	40.1	
Oxygen Index %	28	D2863

