

RELIEF, BY-PASS, BACK PRESSURE & ANTI-SIPHON VALVES

Angle and In-Line Designs for Corrosive Chemicals, Water and Ultra-Pure Liquids providing smooth sensitive operation

Applications:

- Handle highly corrosive or ultra pure liquids.
- Provide by-pass flow relief to avoid pumping problems.
- Prevent overpressures in vessels and piping systems.
- Maintain back pressure in piping systems.
- Prevent gravity-induced siphon through pump.
- Enhance pump performance.
- 2-port and 3-port designs.
- 1/4" through 3" pipes sizes in PVC, CPVC, Natural Polypro, Glass-Filled Polypro, PVDF and PTFE.

Performance:

- Set pressure adjustable from 5 to 150 psi.
- Inlet pressure rating up to 210 psi.
- Flow rates up to 200 gpm.
- Multi-million cycle designs.

Features:

- Offer wide range of pressure settings with sensitive operation.
- Provide smooth operation with less pressure drop.
- Fail-Dry® safety feature.
- No wetted metals.
- Each valve is individually tested prior to shipment.
- Stainless steel fasteners standard.
- Rugged thermoplastic construction.
- Maintenance free designs.
- Designs for crystallizing liquids.
- Designs with no wetted elastomers.
- Factory pre-set if requested.
- Tamper-proof option.
- Field proven performance since 1967.



PLAST-O-MATIC VALVES, INC.

1384 Pompton Avenue, Cedar Grove, New Jersey 07009-1095
(973) 256-3000 • Fax (973) 256-4745 • www.plastomatic.com

RELIEF VALVES FOR CORROSIVE AND ULTRA PURE LIQUIDS

| VALVE SELECTION CHART | STYLES & FEATURES | | | | | | | | | | APPLICATIONS | | | | | BODY MATERIALS | | | | SIZES | | | | | FLOW | | | |
|-----------------------|-------------------|-----------------|-----------|-------------------|----------------|----------------|-------------------------|----------------------|-----------------------|-----------------------|----------------------------|-----|------|-----------------|----------------------|----------------|------|------|------|-------|----|--------|--------|----|------|---------------------------|--------------------|-------|
| | ANGLE PATTERN | IN-LINE PATTERN | DIAPHRAGM | ROLLING DIAPHRAGM | PTFE DIAPHRAGM | FAIL-DRY SHAFT | PRESSURE-BY-PASS RELIEF | BACK PRESSURE RELIEF | ANTI-SIPHON REGULATOR | SPIGOT ENDS AVAILABLE | OK W/CRYSTALLIZING LIQUIDS | PVC | CPVC | NATURAL POLYPRO | GLASS-FILLED POLYPRO | PTFE | PVDF | 1/4" | 1/2" | 3/4" | 1" | 1-1/4" | 1-1/2" | 2" | 3" | MAX. INLET PRESSURE (PSI) | SET PRESSURE RANGE | |
| RVD | ● | ● | | | | ○ | ○ | ● | ● | | ● | ● | ● | ● | ● | ● | ● | ● | ● | ● | ● | ● | ● | ● | ● | 210 | 5-150 | RVD |
| RVDM | | ● | ● | ● | ● | ● | ● | ● | ● | ● | ● | ● | ● | ● | ● | ● | ● | ● | ● | ● | ● | ● | ● | ● | ● | 150 | 5-100* | RVDM |
| RVT | ● | | | ● | ● | ● | ● | ● | ● | ● | ● | ● | ● | ● | ● | ● | ● | ● | ● | ● | ● | ● | ● | ● | ● | 150 | 5-100 | RVT |
| RVTX | ● | | ● | | | ● | ● | ● | ● | ● | ● | ● | ● | ● | ● | ● | ● | ● | ● | ● | ● | ● | ● | ● | ● | 150 | 5-100 | RVTX |
| RVDT | | ● | ● | | ● | ● | ● | ● | ● | ● | ● | ● | ● | ● | ● | ● | ● | ● | ● | ● | ○ | ● | ● | ● | ● | 150 | 5-100 | RVDT |
| TRVDT | | ● | ● | | ● | ● | ● | ● | ● | ● | ● | ● | ● | ● | ● | ● | ● | ● | ● | ● | ● | ● | ● | ● | ● | 150 | 5-100 | TRVDT |

○ – Depends on application, consult factory.

*5-120 for 1/2" size.

Contents & Quick Guide

RVD

- Most economical
- Angle pattern, 1/4" and 1/2" sizes
- Barrier type seal (flat elastomer diaphragm)
- High pressure ratings

PAGE

3

RVDM

- In-line pattern with "Fail-Dry®"
- 1/2", 3/4", and 1" sizes
- Barrier type seal (elastomer rolling diaphragm)

4

RVT

- Angle pattern with "Fail-Dry"
- Complete 1/2" through 2" pipe sizes
- Sliding U-cup seal: Not for use with crystallizing liquids

5

RVTX

- 200 GPM capacity
- Angle pattern, 3" size only
- Barrier-type seal (elastomer rolling diaphragm)

6

RVDT

- Highest flow at lowest overpressure
- In-line pattern, 1/4" through 2" sizes with "Fail-Dry"
- Barrier type seal (flat PTFE diaphragm)
- No wetted elastomers

7

TRVDT

- 3-port design for by-pass applications
- 1/2", 3/4" and 1" sizes with "Fail-Dry®"
- Barrier type seal (flat PTFE diaphragm)
- No wetted elastomers

8

Applications

Relief Valve Selection
Sample Specifications
Fail-Dry® Valves

10

12

APPLICATION DIAGRAM

Illustrating The Multi-Functions Of Plast-O-Matic's Relief Valves

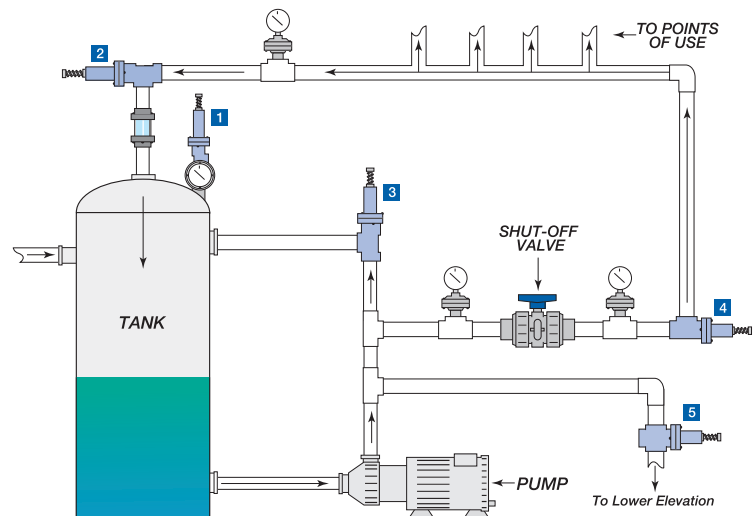

- 1 "Pressure Relief Valve"**, to protect a system (e.g. pump, pipe segment or tank) from excessive pressure (in excess of the set point).
- 2 "Back Pressure Regulator"**, to provide a means of retaining desired system pressure to points of use in upstream line(s).
- 3 "By-Pass Relief Valve"**, to protect a pump from "dead heading" by enabling the flow to by-pass an obstruction back to the tank or pump.
- 4 "Back Pressure Valve"**, to provide back pressure directly on the discharge of a pump to enhance its performance.
- 5 "Anti-Siphon Valve"**, to prevent unwanted chemical siphoning, if pressure drops to zero, and changes in elevation create negative pressure.

NOTE: Pressure Relief, By-Pass Relief and Anti-Siphon Valves may require piping tee which eliminates the need for 3-port valve.

SERIES RVD • Single Diaphragm Design



**compact and economical;
ideal for low through high pressure applications**

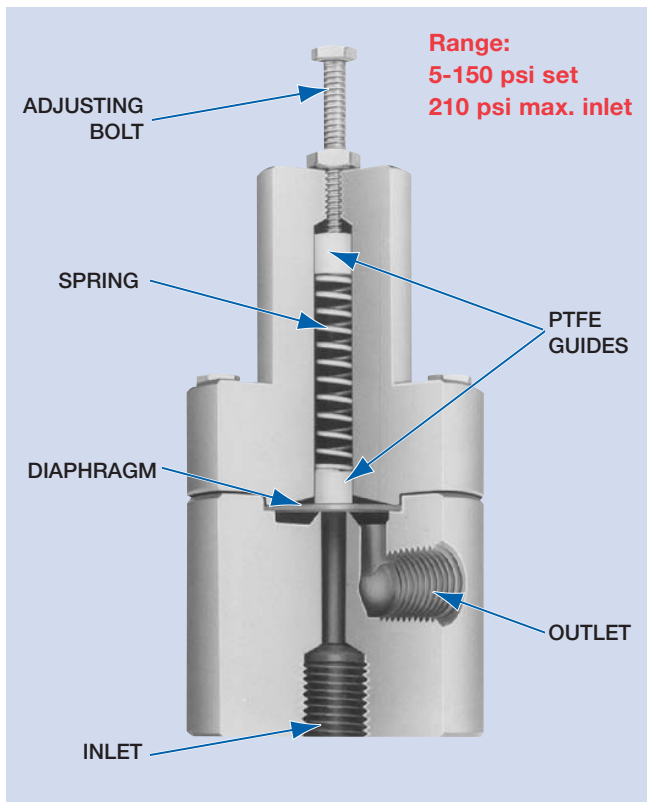

Features:

- Single diaphragm provides quick response, prevents crystallization.
- PTFE guides designed for smooth, chatter-free operation.
- Heavy-duty; machined from solid thermoplastics and built for corrosive applications.
- Designed for low maintenance and easy to adjust.
- Angle pattern in 1/4" and 1/2" pipe sizes.
- No wetted metal parts.

Design:

Series RVD angle pattern pressure relief valves features a single flat diaphragm which is an advantage where salt crystallization problems can cause valve sticking. Relief setting is infinitely adjustable from 5 psi to 150 psi. Maximum inlet pressure is 210 psi.

Materials of Construction:

Available in PVC, Natural Polypropylene, PVDF and PTFE. Seals are available in EPDM or FKM (Viton®). The adjusting bolt, lock nut and fasteners are stainless steel. The control spring is plated steel. No metal parts are in contact with liquid.

Series RVD Model Numbers

| PIPE SIZE | PVC Model No. | POLYPRO* Model No. | PVDF Model No. | PTFE Model No. |
|-----------|---------------|--------------------|----------------|----------------|
| 1/4" | RVD025V-PV | RVD025V-PP | RVD025V-PF | RVD025V-TF |
| 1/2" | RVD050V-PV | RVD050V-PP | RVD050V-PF | RVD050V-TF |

*Natural unpigmented polypropylene.
Shown with FKM seals. For EPDM Seals change "V" to "EP"

**EVERY
PLAST-O-MATIC
VALVE IS
INDIVIDUALLY
TESTED PRIOR TO
SHIPMENT.**

Series RVD Flow Characteristics

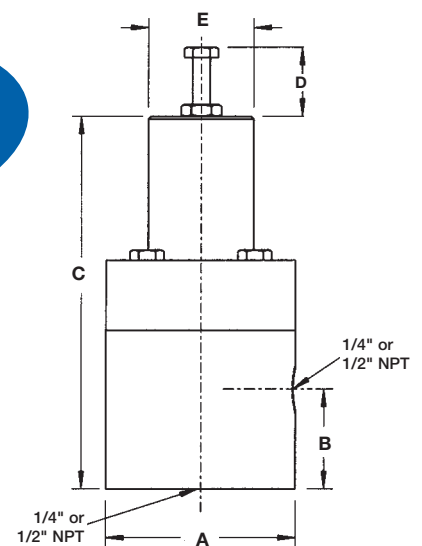
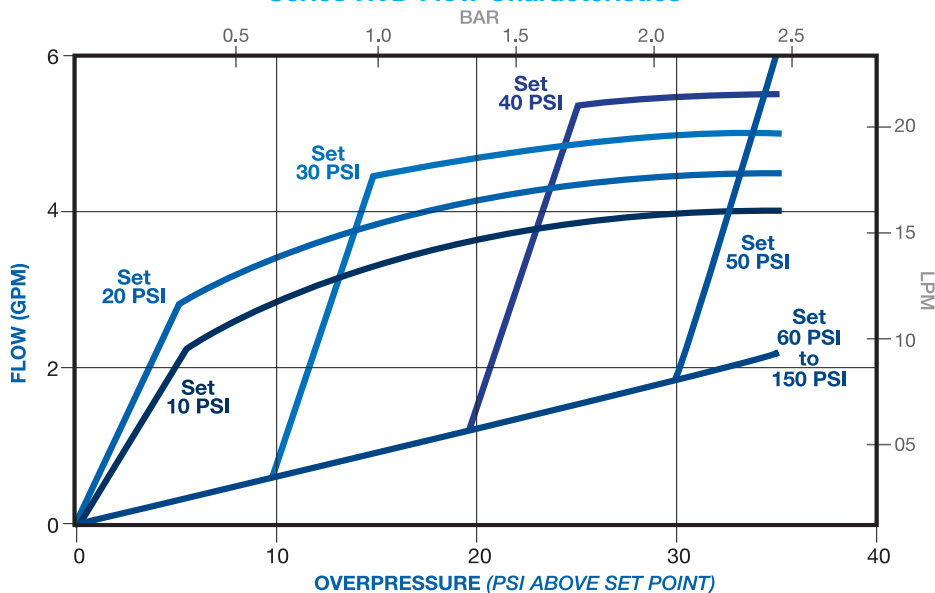

Series RVD Dimensions

| | NPT or BSP | | | |
|----------|------------|-------|-------|-------|
| | 1/4 | | 1/2 | |
| | in. | mm. | in. | mm. |
| A | 2 | 50.8 | 2.375 | 60.3 |
| B | 1.125 | 2.85 | 1.500 | 38.1 |
| C | 4 | 100.6 | 4.687 | 119.0 |
| D | 1.125 | 28.5 | 1.125 | 28.5 |
| E | 1.125 | 28.5 | 1.125 | 28.5 |

SERIES RVDM • Rolling Diaphragm Design

eliminates crystallization problems; smooth, sensitive operation for corrosive and high purity liquids

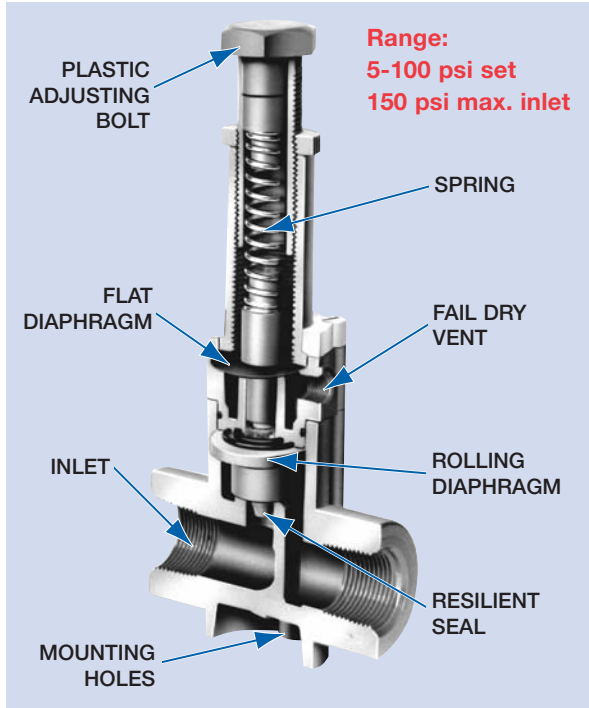
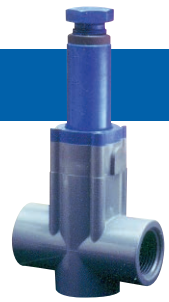

Features:

- Rolling diaphragm provides high accuracy, prevents crystallization.
- Flat secondary diaphragm provides a second isolation of the control spring.
- Patented Fail-Dry® safety vent gives advance warning of need to replace primary seal.
- In-line pattern in 1/2", 3/4" and 1" pipe sizes.
- No wetted metals.

Design:

Series RVDM in-line pressure relief valve features a primary rolling diaphragm and a secondary flat diaphragm which incorporates the Plast-O-Matic patented Fail-Dry design for added protection. Relief setting is infinitely adjustable from 5 psi to 100 psi. 1/2" size to 120 psi. Maximum inlet pressure is 150 psi. Not recommended for applications with vacuum or backpressure on the outlet.

Materials of Construction:

Available in PVC, CPVC, Glass-Filled Polypropylene and PVDF. Seals are available in EPDM or FKM (Viton®). The valve adjusting bolt, lock nut, and body are thermoplastic. Support washers in Polypro models are made of PVDF. The plated steel control spring and stainless steel external fasteners are not in contact with liquid.

Series RVDM Dimensions

| | 1/2 | | 3/4 | | 1 | |
|---|------|-------|-----|-------|-----|-------|
| | in. | mm. | in. | mm. | in. | mm. |
| A | 2.25 | 57.1 | 4.0 | 101.6 | 4.0 | 101.6 |
| B | 4.12 | 104.1 | 4.0 | 101.6 | 4.4 | 101.6 |
| C | 2.88 | 73.7 | 3.3 | 83.8 | 3.3 | 83.8 |
| D | 0.94 | 24.0 | 1.3 | 33.3 | 1.3 | 33.3 |
| E | 1.50 | 38.1 | 1.5 | 38.1 | 1.5 | 38.1 |
| F | 1.88 | 48.0 | 1.9 | 48.0 | 1.9 | 48.0 |

Series RVDM Model Numbers

| NPT or BSP | PVC Model No. | POLYPRO Model No. | CPVC Model No. | PVDF Model No. |
|------------|---------------|-------------------|----------------|----------------|
| 1/2 | RVDM050EP-PV | RVDM050EP-PP | RVDM050EP-CP | RVDM050EP-PF |
| 3/4 | RVDM075EP-PV | RVDM075EP-PP | RVDM075EP-CP | RVDM075EP-PF |
| 1 | RVDM100EP-PV | RVDM100EP-PP | RVDM100EP-CP | RVDM100EP-PF |

Model numbers shown are for EPDM seals. For FKM, change "EP" to "V".

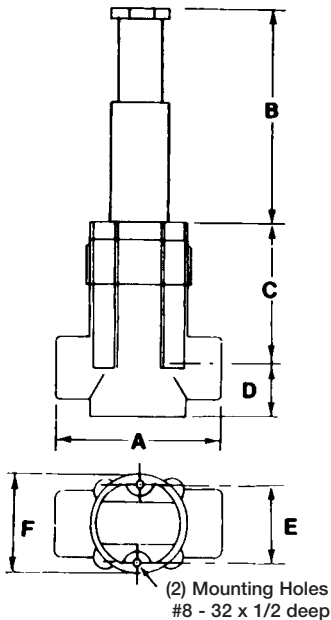

Series RVDM Flow Characteristics

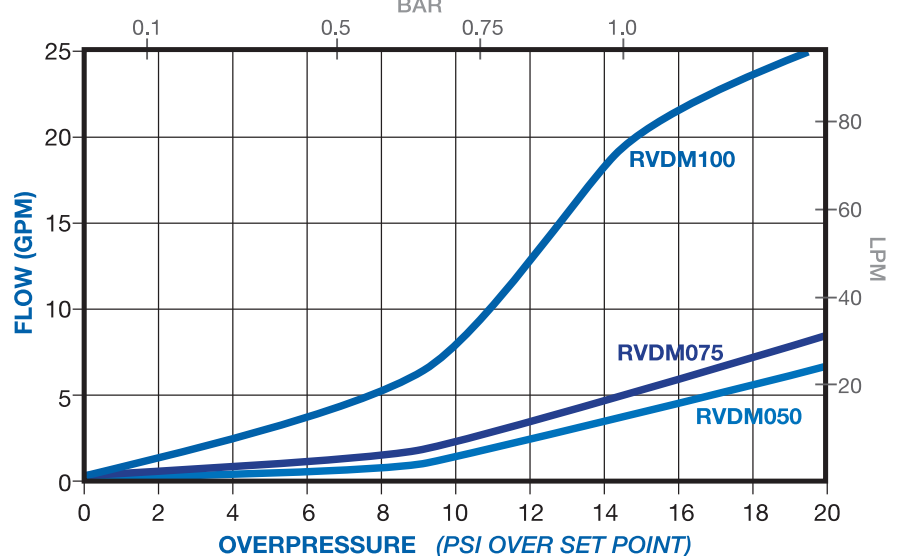

SERIES RVT • Solid PTFE Shaft Design



angle pattern valve with high pressure and flow rates

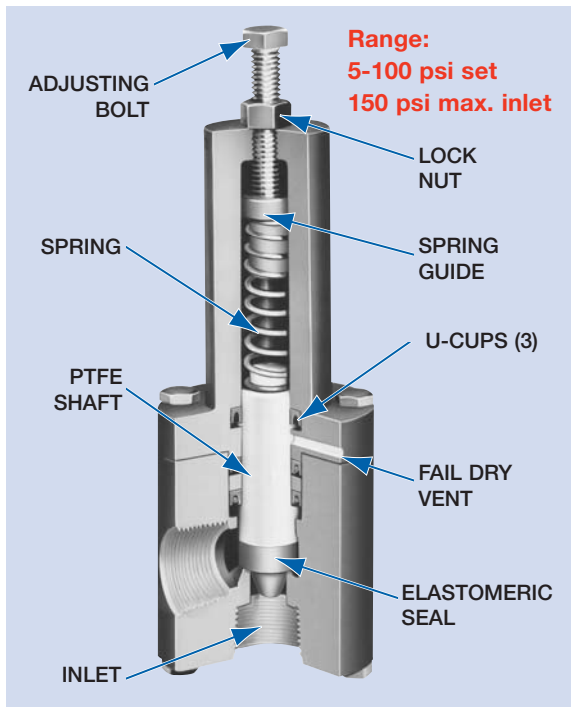

Features:

- PTFE shaft prevents chatter and sticking.
- Triple U-cup seal isolates spring, provides added safety.
- Patented Fail-Dry® advance warning vent allows maintenance to be scheduled conveniently, without costly shut-down.
- Angle pattern offers compact size and convenient piping.
- 1/2" through 2" pipe sizes.
- No wetted metal parts.

Design:

Series RVT angle pattern pressure relief valve features a solid, non-sticking PTFE shaft passing through three U-cup seals. It is a proven, high performance relief valve providing rugged dependability for acids and other highly corrosive liquids. Relief setting is infinitely adjustable from 5 psi to 100 psi. Maximum inlet pressure is 150 psi. Not recommended for salt solutions and other liquids that can crystallize.

Materials of Construction:

Available in PVC, CPVC, Natural Polypropylene, PVDF and PTFE. Seals are available in EPDM or FKM (Viton®). For alternate body or seal materials, consult factory. The adjusting bolt, lock nut and fasteners are stainless steel. The control spring is plated steel. No metal parts are in contact with liquid.

Series RVT Dimensions

| NPT or BSP | A | | B | | C | | D | | E | |
|--|------|-------|-------|------|-------|-------|-------|------|-------|------|
| | in. | mm. | in. | mm. | in. | mm. | in. | mm. | in. | mm. |
| For PVC (PV), Polypro (PP), PTFE (TF), PVDF (PF) Bodies | | | | | | | | | | |
| 1/2 | 2.5 | 63.0 | 1 | 55.0 | 5 | 127.0 | 1.25 | 31.0 | 1.25 | 31.0 |
| 3/4 | 3 | 76.0 | 2.25 | 57.0 | 5.375 | 137.0 | 1.25 | 31.0 | 1.5 | 38.0 |
| 1 | 3 | 76.0 | 2.25 | 57.0 | 5.562 | 141.0 | 2 | 51.0 | 1.5 | 38.0 |
| 1 1/4 | 4 | 101.6 | 2.5 | 63.5 | 7.625 | 193.6 | 2 | 50.8 | 2 | 50.8 |
| 1 1/2 | 4.5 | 114.0 | 3.875 | 98.0 | 7.125 | 181.0 | 2.25 | 57.0 | 2.25 | 57.0 |
| 2 | 5.5 | 140.0 | 3.875 | 98.0 | 8.5 | 216.0 | 2.625 | 67.0 | 2.75 | 70.0 |
| CPVC (Corzan™) Body | | | | | | | | | | |
| 1/2 | 2.5 | 63.5 | 1 | 25.4 | 5 | 127.0 | 1.25 | 31.7 | 1.25 | 31.7 |
| 3/4 | 2.5 | 63.5 | 1.5 | 38.1 | 5.25 | 133.3 | 1.5 | 38.1 | 1.5 | 38.1 |
| 1 | 3.0 | 76.2 | 1.75 | 44.4 | 5.5 | 139.7 | 1.75 | 44.4 | 1.75 | 44.4 |
| 1 1/4 | 3.5 | 88.9 | 2.5 | 63.5 | 7.625 | 193.6 | 2 | 50.8 | 2 | 50.8 |
| 1 1/2 | 3.75 | 95.2 | 2 | 50.8 | 7 | 177.8 | 2.187 | 53.9 | 2.125 | 53.9 |
| 2 | 4.25 | 109.7 | 3.25 | 82.5 | 8.5 | 215.9 | 2.5 | 61.2 | 2.25 | 57.1 |

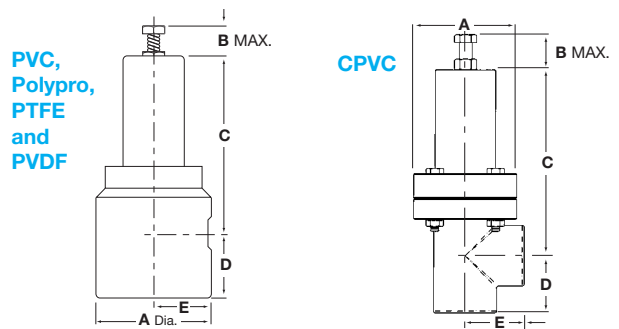

Series RVT Model Numbers

| PIPE SIZE | PVC* Model No. | POLYPRO Model No. | PVDF Model No. | PTFE Model No. |
|-----------|----------------|-------------------|----------------|----------------|
| 1/2 | RVT050V-PV | RVT050V-PP | RVT050V-PF | RVT050V-TF |
| 3/4 | RVT075V-PV | RVT075V-PP | RVT075V-PF | RVT075V-TF |
| 1 | RVT100V-PV | RVT100V-PP | RVT100V-PF | RVT100V-TF |
| 1 1/4 | RVT125V-PV | N/A | N/A | N/A |
| 1 1/2 | RVT150V-PV | RVT150V-PP | RVT150V-PF | RVT150V-TF |
| 2 | RVT200V-PV | RVT200V-PP | RVT200V-PF | RVT200V-TF |

* For CPVC change -PV to -CP.

Series RVT 1/2", 3/4" and 1" Flow Characteristics

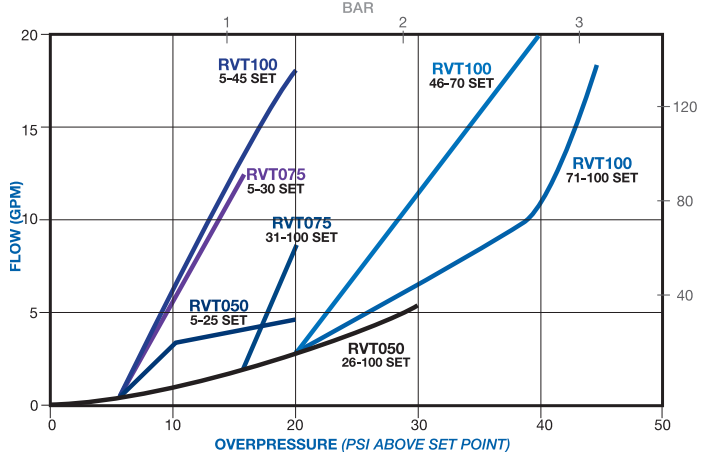

Series RVT 1 1/4", 1 1/2" and 2" Flow Characteristics

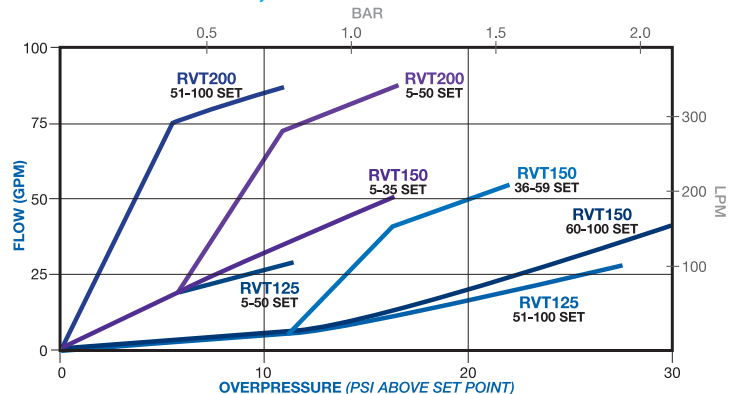

SERIES RVTX • Rolling Diaphragm Design



a super-high performance 3" relief valve

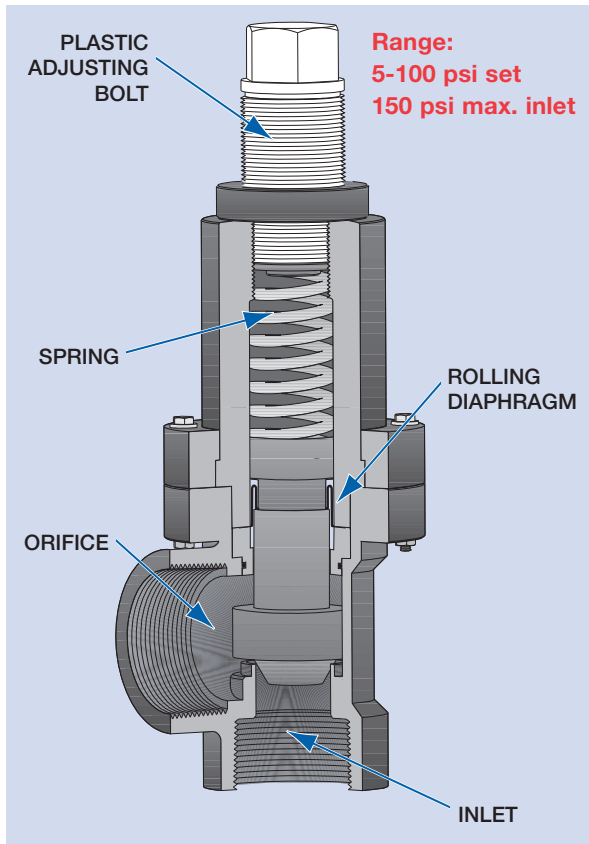

Features:

- Large area rolling diaphragm provides precise, sensitive operation.
- Ideal for use with liquids that crystallize.
- Heavy-duty industrial construction.
- Angle pattern offers compact size and convenient piping.
- 3" pipe size.
- No wetted metal parts.

Design:

Series RVTX angle pattern pressure relief valve features a solid, PVC shaft with a PTFE thrust washer for reduced friction, working in conjunction with a large area rolling diaphragm. This high flow capacity relief valve provides rugged dependability for acids, salt solutions, and other highly corrosive liquids. Relief setting is infinitely adjustable from 5 psi to 100 psi. Maximum inlet pressure is 150 psi. Not recommended for applications with a vacuum on the outlet.

Materials of Construction:

Available in PVC. Thrust washer is PTFE. Seals are available in EPDM and FKM (Viton®). For other body or seal materials, consult factory. The valve adjusting bolt and lock nut are high density polyethylene. The control spring is plated steel. The fasteners are stainless steel. No metal parts are in contact with liquid.

Series RVTX Flow Characteristics

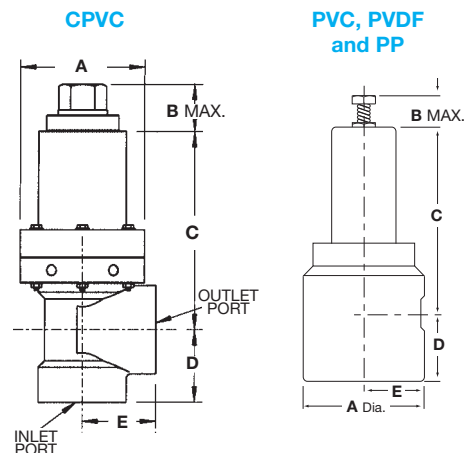
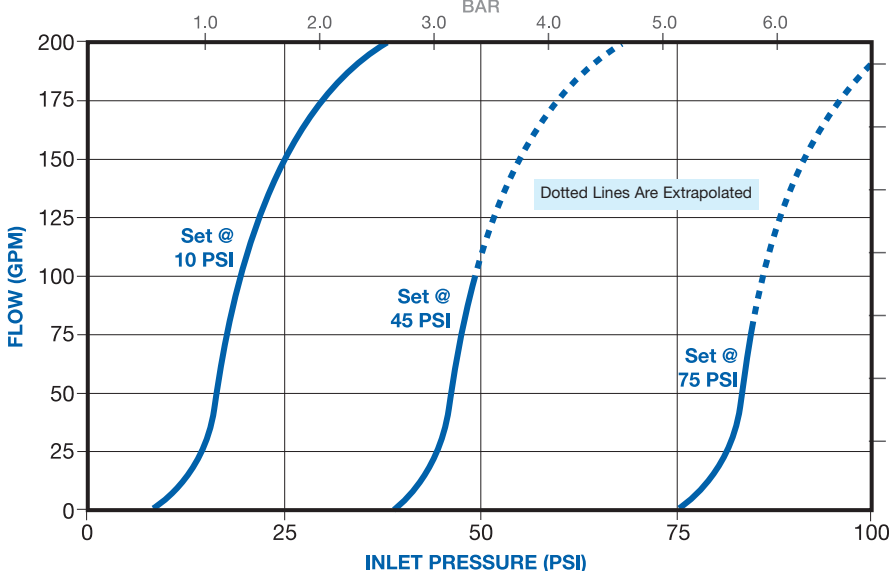

Series RVTX Dimensions

| | CPVC | | PVC, PP & PVDF | |
|---|------|-------|----------------|-------|
| | in. | mm. | in. | mm. |
| A | 6.0 | 152.4 | 7.0 | 177.8 |
| B | 2.3 | 58.4 | 4.5 | 114.3 |
| C | 9.6 | 243.8 | 9.8 | 248.9 |
| D | 3.5 | 88.9 | 3.8 | 96.5 |
| E | 3.6 | 91.4 | 3.5 | 88.9 |

EVERY PLAST-O-MATIC VALVE IS INDIVIDUALLY TESTED PRIOR TO SHIPMENT.

Series RVTX Model Numbers

| PIPE SIZE | EPDM Model No. | FKM Model No. |
|-----------|----------------|---------------|
| 3" | RVTX300EP-PV | RVTX300V-PV |

For CPVC, change -PV to -CP, example RVTX300V-CP.
For Polypro, change -PV to -PP, example RVTX300V-PP.

SERIES RVDT • PTFE Diaphragm Design



the ultimate in corrosion resistance
with no wetted metals or elastomers!

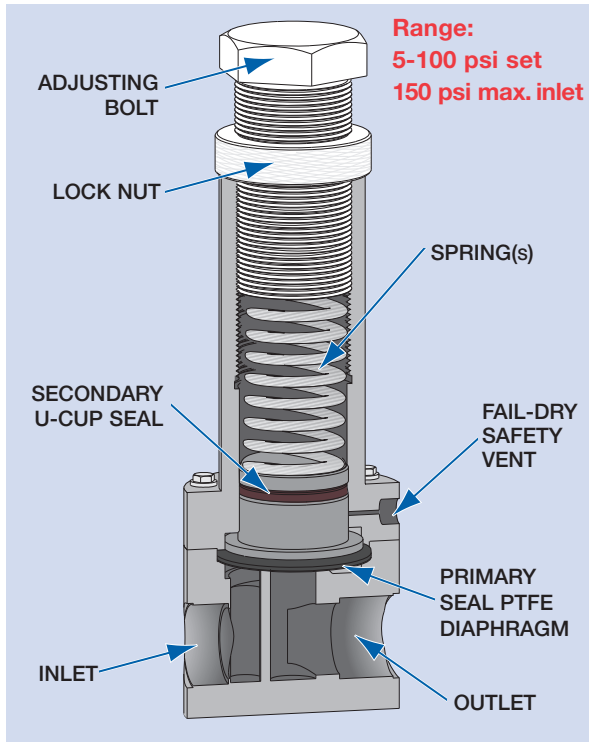

Features:

- One valve design functions as a relief valve, by-pass valve, back-pressure valve and anti-siphon valve.
- PTFE diaphragm – no wetted metal or elastomeric parts.
- Unique PTFE diaphragm is excellent for use with highly aggressive liquids... and also provides the ultimate in contamination-free sealing.
- Rugged thermoplastic construction is ideal for a broad range of industrial applications.
- Large diaphragm area delivers more sensitivity and less pressure drop under flow conditions.
- Patented Fail-Dry® safety feature provides visual warning of seal malfunction and permits the valve to continue operation until a scheduled maintenance can be planned.
- Non-leaching feature of PTFE makes it ideal for use with ultra-pure water and concentrated etchants, as in the semiconductor industry.
- Available in 1/4", 1/2", 3/4", 1", 1 1/2" and 2" sizes.

Design:

Series RVDT in-line pressure relief valves feature a wetted flat PTFE diaphragm to resist both chemical attack and salt crystallization problems. A large active diaphragm area provides for smooth, chatter-free operation. Relief setting is infinitely adjustable from 5 psi to 100 psi. Maximum inlet pressure 150 psi. Series RVDT is available in 1/4", 1/2", 3/4", 1", 1 1/2" and 2" pipe sizes.

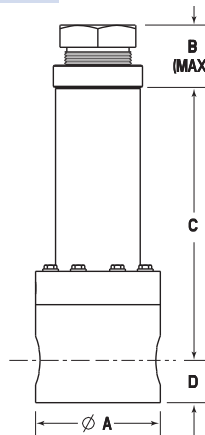

Materials of Construction:

Series RVDT relief valves are available in PVC, Polypropylene, PVDF (Kynar®) and PTFE body materials. The wetted diaphragm is PTFE energized by a non-wetted FKM (Viton®) diaphragm. Springs (not in wetted area) are plated steel and fasteners are stainless steel. Standard spring housing is PVC, and adjusting screw is high-density polyethylene or stainless steel.

Series RVDT Dimensions

| PIPE SIZE NPT | A | | B | | C | | D | |
|---------------|-----|-----|------|-----|------|-----|-------|-----|
| | in. | mm. | in. | mm. | in. | mm. | in. | mm. |
| 1/4 | 2.0 | 50 | 1.38 | 35 | 4.30 | 109 | .470 | 11 |
| 1/2 | 2.5 | 63 | 1.48 | 37 | 4.41 | 112 | .687 | 17 |
| 3/4 | 3.0 | 76 | 2.81 | 71 | 5.39 | 137 | .780 | 19 |
| 1 | 3.5 | 83 | 3.00 | 76 | 7.65 | 194 | 1.187 | 30 |
| 1 1/2 | 5.0 | 127 | 3.50 | 89 | 7.00 | 178 | 1.500 | 38 |
| 2 | 6.0 | 153 | 2.80 | 71 | 8.13 | 207 | 1.750 | 45 |

Series RVDT Typical Flow Characteristic

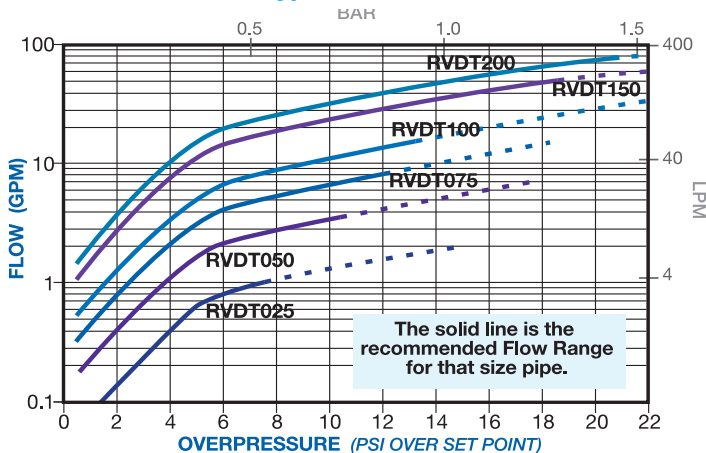

Series RVDT Model Numbers

| PIPE SIZE | PVC Model No. | POLYPRO* Model No. | PVDF Model No. | PTFE Model No. |
|-----------|---------------|--------------------|----------------|-----------------|
| 1/4 | RVDT025V-PV | RVDT025V-PP | RVDT025V-PF | RVDT025V-TF |
| 1/2 | RVDT050V-PV | RVDT050V-PP | RVDT050V-PF | RVDT050V-TF |
| 3/4 | RVDT075V-PV | RVDT075V-PP | RVDT075V-PF | RVDT075V-TF |
| 1 | RVDT100V-PV | RVDT100V-PP | RVDT100V-PF | RVDT100V-TF |
| 1 1/2 | RVDT150V-PV | RVDT150V-PP | RVDT150V-PF | Consult Factory |
| 2 | RVDT200V-PV | RVDT200V-PP | RVDT200V-PF | |

*Natural Polypropylene

SERIES TRVDT • 3-Port Diaphragm Design

Relief: protects systems and equipment from overpressure/pressure surges.

Bypass: prevents pumps from “dead heading”.

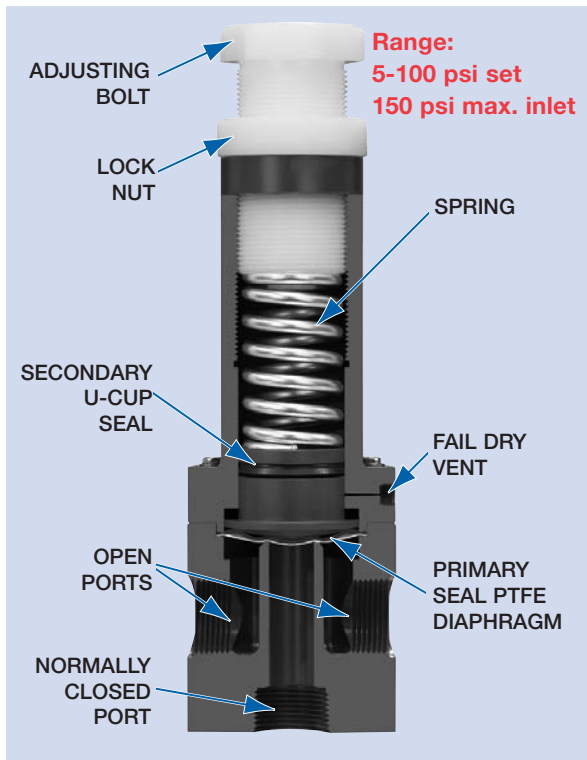

Features:

- Unique PTFE Diaphragm is excellent for use with highly aggressive liquids... and also provides the ultimate in contamination-free sealing.
- Rugged thermoplastic construction is ideal for a broad range of industrial applications.
- Large diaphragm area delivers more sensitivity and less pressure drop under flow conditions.
- Non-wetted U-cup seal provides a second isolation of the control spring; design includes patented Fail-Dry vent, a safety feature that provides visual warning of seal malfunction.
- Non-leaching feature of fluoropolymer diaphragm makes it ideal for use with ultra-pure water and concentrated etchants, as in the semiconductor industry.
- Available in 1/2", 3/4", 1" sizes.

Design:

High flow relief/by-pass valve with 3-port design, ideal for applications where minimal footprint is required or where use of a piping tee is impractical. Valve has a straight-through flow pattern when closed. When set point is exceeded, the diaphragm is lifted off the center port, and excess flows "down" and out through the third port at the bottom of the valve.

For applications where a tee can be accommodated, a 2-port valve such as Series RVDT is usually preferred. If you are unsure which is right for your application, please contact our Technical Services Group at 973-256-3000.

Materials of Construction:

Series TRVDT relief valves are available in Geon® PVC, Natural Polypropylene, Kynar® PVDF and PTFE body materials. The wetted diaphragm is PTFE energized by a non-wetted FKM diaphragm. Spring housing (completely non-wetted) is Geon PVC, but can be constructed of the wetted body material for a slightly higher cost. Springs (not in wetted area) are zinc-plated steel, external fasteners are stainless steel. Lock nut and adjusting screw are HDPE.

Series TRVDT Ordering Information

| Pipe Size | Model Number | | | | |
|-----------|--------------|--------------|--------------|--------------|--------------|
| | PVC | CPVC | Nat. Polypro | PTFE | PVDF |
| 1/2" | TRVDT050V-PV | TRVDT050V-CP | TRVDT050V-PP | TRVDT050V-TF | TRVDT050V-PF |
| 3/4" | TRVDT075V-PV | TRVDT075V-CP | TRVDT075V-PP | TRVDT075V-TF | TRVDT075V-PF |
| 1" | TRVDT100V-PV | TRVDT100V-CP | TRVDT100V-PP | TRVDT100V-TF | TRVDT100V-PF |

Primary seal is PTFE; part numbers above show backing seal of FKM. For EPDM backing seal, change "V" to "EP"; example: TRVDT050EP-PV.

Optional Class 100 Cleanroom CDB procedure available, consult factory

Series TRVDT Dimensions

| Size NPT | A | | B | | C | | D | |
|----------|-----|----|------|----|------|-----|------|------|
| | in. | mm | in. | mm | in. | mm | in. | mm |
| 1/2" | 2.5 | 63 | 1.48 | 37 | 4.40 | 112 | 1.38 | 35.1 |
| 3/4" | 3.0 | 76 | 2.81 | 71 | 5.50 | 140 | 1.66 | 42.3 |
| 1" | 3.5 | 87 | 3.00 | 76 | 7.65 | 195 | 1.94 | 49.4 |

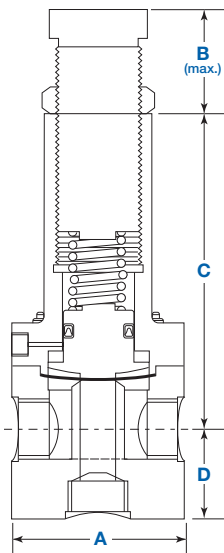



Flow Characteristics at Overpressure:

Curves show flow rate under laboratory conditions at various pressures exceeding the set point; i.e. flow characteristics with third port open. Dashed portion of curve indicates flow rate exceeds universally accepted safe flow velocity (5 ft./sec.) for that pipe size.

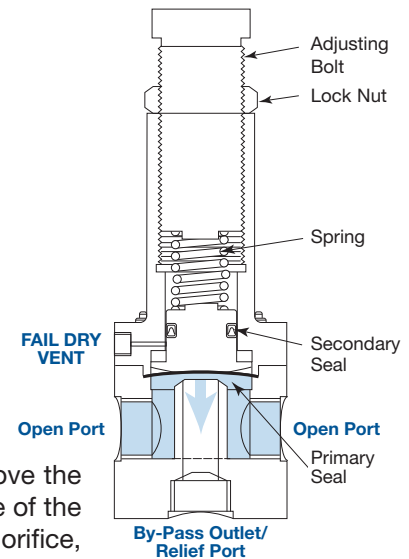
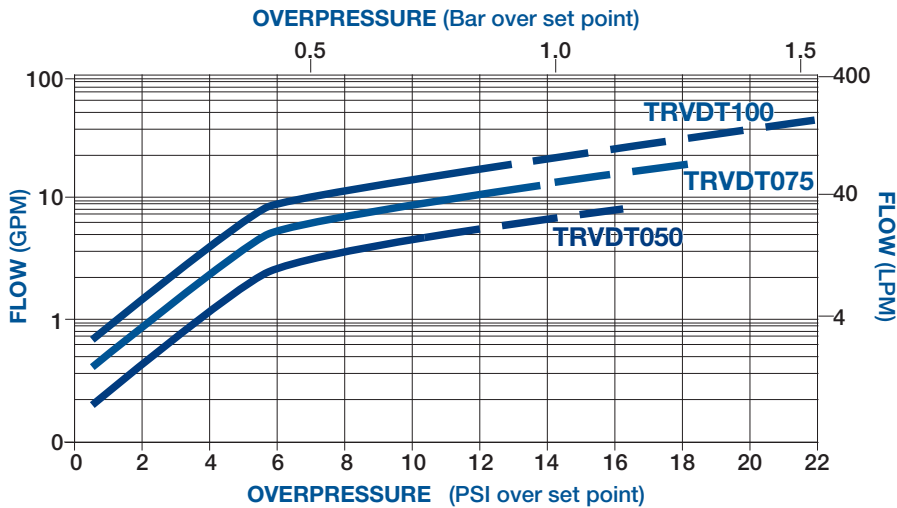

Cv of Open Ports

| Size | Cv |
|------|-----|
| 1/2" | 2.5 |
| 3/4" | 4.0 |
| 1" | 6.5 |

Illustration of Flow Path and Operation:

In the illustration to the right, liquid pressure has risen above the set pressure. The force of the liquid now exceeds the force of the spring; the pressure lifts the diaphragm off the relief port orifice, allowing liquid to flow down and through the relief port. In this way it "relieves" the pressure in the line.

Difference Between 2-Port and 3-Port Relief Valves

3 Port Relief Valve

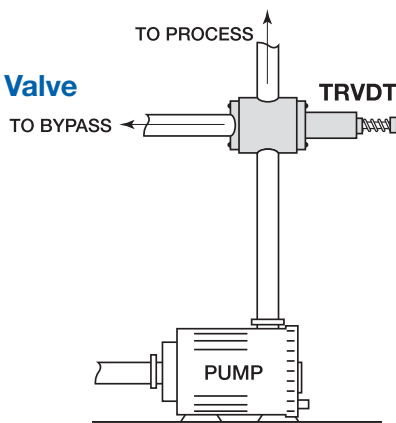

2 Port Relief Valve

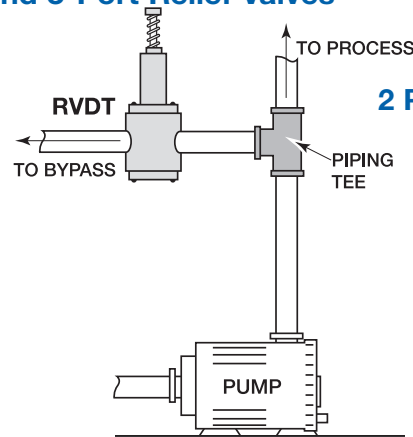

Advantages of a 3-Port Design:

- Smaller "footprint" in a system.
- No need for additional piping tee.
- Easy replacement in existing system using a 3-port valve.

Advantages of a 2-Port Design:

- 2-port relief valve can also be used as a backpressure regulator and an anti-siphon valve; 3-port cannot.
- Choice of in-line or angle pattern increases versatility in piping design.
- Flow capacity is better; 2-port valves provide less restriction and less deadleg.

2-Port relief valves require a piping tee for by-pass and relief applications, but not for backpressure or anti-siphon applications. Unlike 3-port style valves which are placed directly in-line and cause a drop in both pressure and flow, a valve "teed" off in the line usually offers the best system design and ease of maintenance.

In most relief and by-pass applications, 3-port valves do not perform as well as 2-port valves installed on a tee. No 3-port relief is suitable for use as a backpressure regulator or anti-siphon valve, and no 3-port relief valve will deliver the flow and performance of a Plast-O-Matic 2-port relief valve.

BY-PASS EXCESSIVE PRESSURE

Process Fluid: Ground Water

Inlet Pressure/Temperature: Varying / Ambient

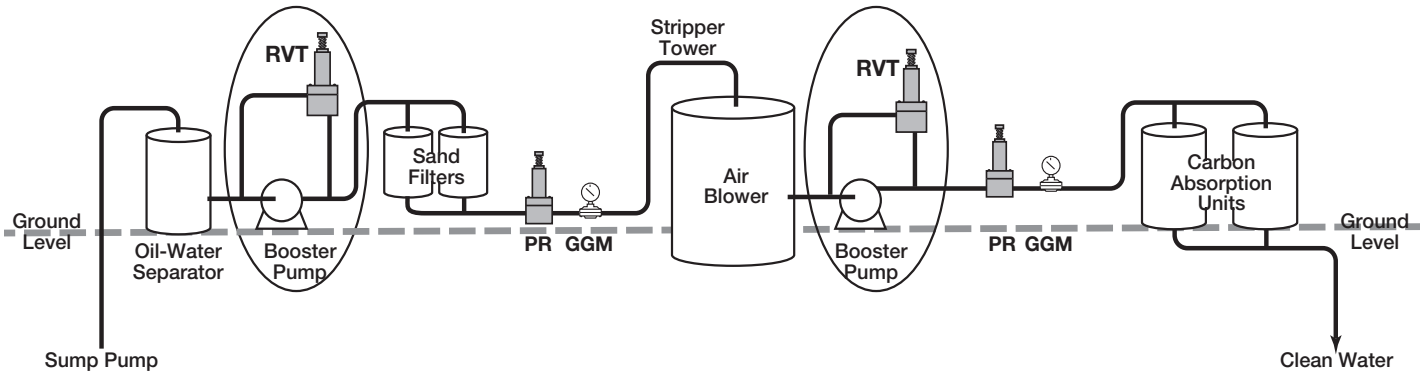

During the remediation process for ground water, the water passes through several different pieces of equipment. Relief Valves are used in the system to protect the pump from dead heading, should one of the pressure regulators close. As the pressure regulator reaches the set pressure and closes, the normally-closed relief valve senses the increase in system pressure and begins to open, diverting the flow back to the suction side of the pump. When the pressure regulator opens again, the relief valve senses the decrease in pressure and begins to close, allowing normal flow patterns to resume.

ANTI-SIPHON AND BY-PASS PROTECTION

Process Fluid: Various Organics

Inlet Pressure/Temperature: Gravity to 100 PSI / 72°F

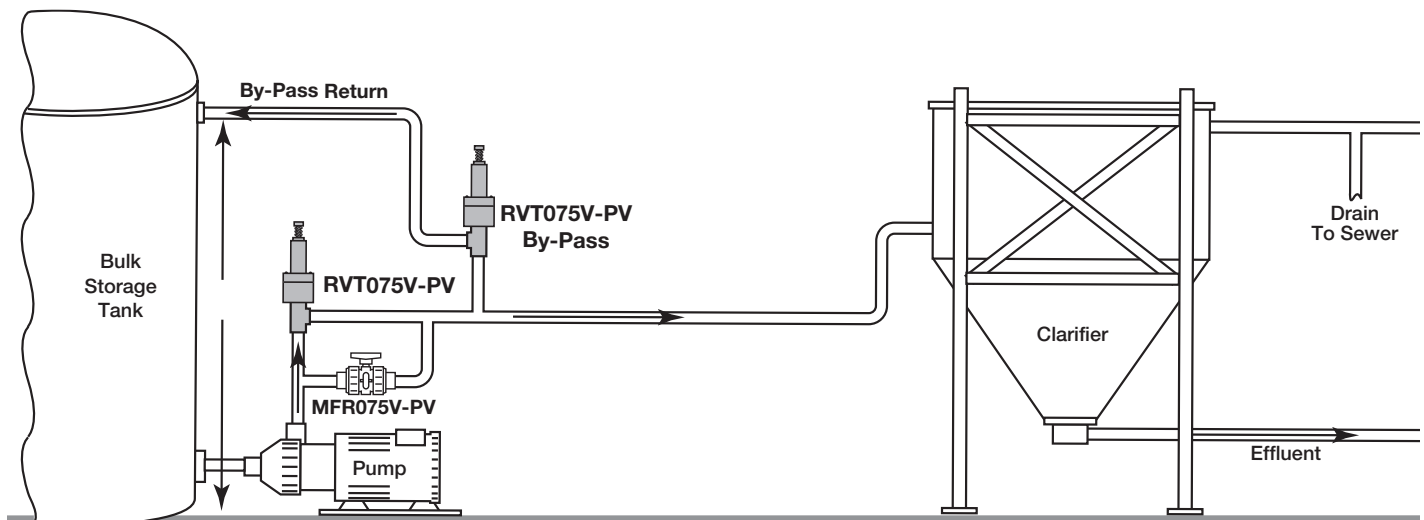

A major clarifier manufacturer required a reliable, weather resistant mechanical method of preventing bulk tank siphoning when their clarifier system was down/off. Plast-O-Matic Series RVT Relief Valve was specified for its pressure set range of 5-100 PSI. By setting the RVT at 10 PSI, the possibility of the tank's 16' head siphoning was eliminated when the pump was of. Additionally, the maximum pressure rating of RVT was well over the pump's maximum of 100 PSI. The RVT's solid PTFE shaft, standard stainless steel fasteners and Fail-Dry® system offered obvious value added benefits. To further ensure system reliability, a manual spring return or "dead man" valve by-pass method was required. Plast-O-Matic spring return palm or foot operated Series MFR was selected for its high flow and compact size. The MFR Series valve eliminated the possibility of a worker accidentally forgetting to close a manual by-pass valve (i.e. ball valve) and draining the tank. The Series RVT was also specified as an emergency by-pass valve to protect the pump from "dead heading."

PROVIDE PROPER PRESSURES AND FLOWS TO DIALYSIS STATIONS

Process Fluid: Acidified (salt) solutions and D.I. water, 15.8 megohm

Inlet Pressure/Temperature: 30 PSI / Ambient

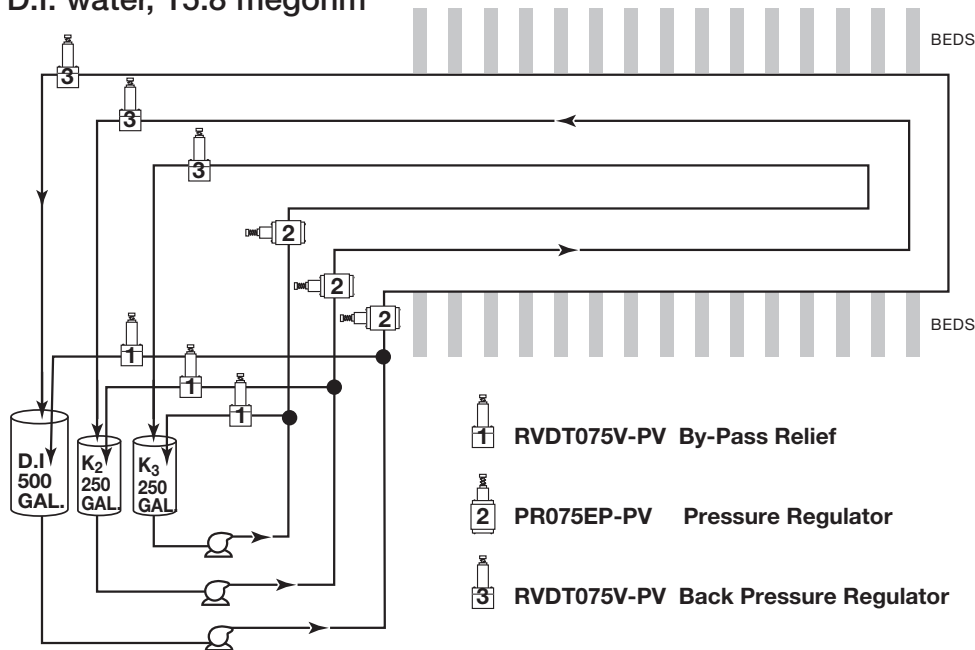

Dialysis center, consisting of 30 stations (beds), was having difficulty in delivering 0.014 GPM at 1 to 8 PSI thru 950 feet of 3/4" pipe to each station with a pump delivering 5 GPM at approximately 32 PSI. They were finding that front-end stations were being subjected to high pressures while those towards the end were not being provided the sufficient pressure nor flows. The installation of a 3/4" Series RVDT valve as a by-pass between the pump and the Series PR Pressure Regulator took off a lot of the excess flow, while the Series PR (set at 8 PSI) assured that the closed loop pressures would not exceed the 8 PSI maximum. Lastly, the installing of another Series RVDT as a back pressure regulator, set at 5 PSI, further assured a 5 PSI (mid-range) system (loop) pressure.

PVC with EPDM seals was found to be compatible with both solutions, as well as economical.

PREVENT SIPHONING THROUGH PUMP IN A PAPER MILL

Process Fluid: Soap and Water

Inlet Pressure/Temperature: 50 PSI

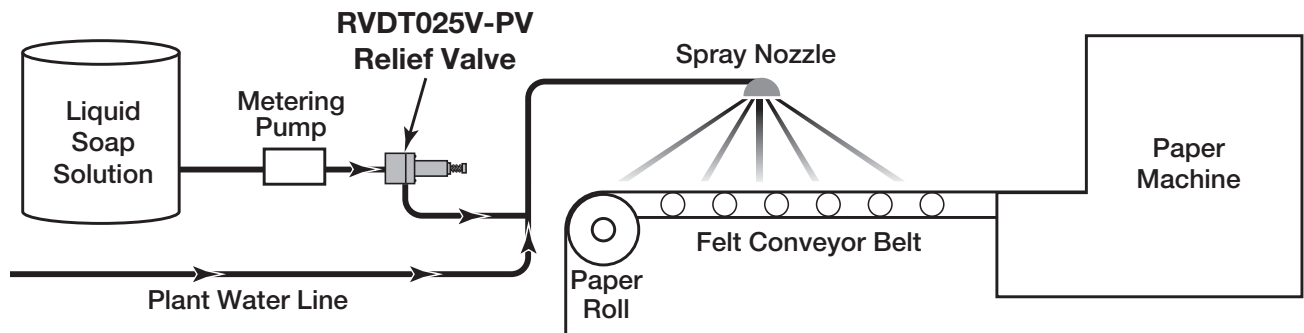

As paper stock leaves the machine it is wet and proceeds through a de-watering process. The conveyor is laid with felt to prevent the paper from becoming dirty. To keep the felt clean it is periodically sprayed with a liquid soap solution, followed by a water rinse. The Series RVDT Relief Valve was selected for use as an anti-siphon valve to prevent the soap solution from being drawn into the spray nozzles when the pump is off and the rinse water feed is in progress.

NOTE: Application bulletins are intended only to show possible applications of Plast-O-Matic products and are not design recommendations for a system or its safety

RELIEF VALVE SELECTION adjustment, operation, sizing and installation

Adjustment: To adjust relieving pressure simply turn adjusting bolt down to increase and up to decrease pressure setting.

Operation: Once the Plast-O-Matic relief valve is set the valve will remain closed as long as the tank or line pressure does not reach the set pressure. The valve will begin to weep or relieve when the set pressure is reached and will require an over-pressure to fully open. When the pressure falls below the set pressure the valve will again close.

Sizing: To determine the proper size relief valve required, it is necessary to know how many gallons per minute of liquid must pass through the valve and the allowable pressures to achieve that flow. Keep in mind that the relief valves open gradually as they build up to the maximum flow rates depending on the amount of overpressure present.

The next step is to consult the flow reference chart. The chart recommends the maximum flow to be used with each valve size and the overpressure required to reach that flow. Overpressure is the amount of pressure needed beyond the set pressure.

CAUTION: RV Series are not "POP SAFETY" valves and should not be used in applications requiring such valves.

Installation: Several control springs are supplied so that the user can select the spring having the proper pressure range in order to set the valve at the desired relief setting.

Before installing the valve in the line, follow the procedure for setting the relief pressure as recommended on the instruction sheet supplied with the valve.

The relief valve should be mounted upright in applications where particulate may settle, and should be installed as near as possible to the line or equipment being protected.

All threaded connections should have an acceptable pipe sealant to effect a good seal. Use care with PTFE tape so that it does not "string". Loose "strings" could lay across the valve seat and prevent it from closing completely. The assembly need only be made hand-tight followed by a one-quarter turn with a strap wrench. Do not overtighten or breakage will result. Never use pipe wrenches, channel pliers, or metal pipe nipples which could distort or cut into the plastic and cause a fracture.

SAMPLE SPECIFICATIONS

Series RVD

Thermoplastic [material] pressure relief valve, [1/4" or 1/2"] NPT threads*, is to be 90° angle pattern featuring a one piece [elastomer] diaphragm for sealing. The valve is to have a solid, machined and polished PTFE plunger in the spring chamber; and stainless steel external fasteners. Manufacturer shall factory set the pressure relief valve at ____PSI....

Series RVDM

Thermoplastic [material] pressure relief valve [size] NPT threads*, is to be in-line ported with molded, fabric reinforced [elastomer] rolling diaphragm as the primary seal. Adjusting bolt and lock nut are to be all plastic. Valve is to have Fail-Dry® Safety Design incorporating a vented chamber between the rolling diaphragm and a secondary flat diaphragm, with a 1/8" NPT port. Manufacturer shall factory set the pressure relief valve at ____PSI....

Series RVT

Thermoplastic [material] pressure relief valve, [size] NPT threads*, is to be 90° angle pattern featuring three [elastomer] molded U-cups for sealing. The valve is to have a solid, machined and polished PTFE shaft; and stainless steel external fasteners. Valve is to have Fail-Dry® Safety Design incorporating a vented chamber between the middle and upper U-cups to protect the spring chamber. Manufacturer shall factory set the pressure relief valve at ____PSI....

Series RVTX

Thermoplastic [material] pressure relief valve, 3" NPT threads*, is to be 90° angle pattern featuring fabric reinforced [elastomer] rolling diaphragm. The valve is to have a solid, machined and polished shaft with PTFE thrust washer; and stainless steel external fasteners. Manufacturer shall factory set the pressure relief valve at ____PSI....

Series RVDT

Thermoplastic [material] pressure relief valve [size] NPT threads*, is to be in-line ported with flat PTFE diaphragm, backed by FKM (Viton), as the primary seal. Adjusting bolt and lock nut are to be all plastic. Valve is to have Fail-Dry® Safety Design incorporating a vented chamber between the flat diaphragm and a secondary elastomer diaphragm to protect the spring chamber. Manufacturer shall factory set the pressure relief valve at ____PSI....

Series TRVDT

Thermoplastic [material] pressure relief valve [size] NPT threads*, is to be 3-port in-line valve with flat PTFE diaphragm, backed by FKM (Viton), as the primary seal. Adjusting bolt and lock nut are to be all plastic. Valve is to have Fail-Dry® Safety Design incorporating a vented chamber between the flat diaphragm and a secondary elastomer diaphragm to protect the spring chamber. Manufacturer shall factory set the pressure relief valve at ____PSI....

...All units are to be 100% individually tested at the factory. As manufactured by Plast-O-Matic Valves, Inc., Cedar Grove, NJ.

*Change NPT thread specification as required. Add "with tamper-proof option" after pressure setting, if required.

FAIL-DRY® VALVES • The Ultimate in Process Safety

relief valves remain sealed and fully operational – even after primary seal failure

The Fail-Dry Safety System

Under normal conditions, Plast-O-Matic elastomers last over 1,000,000 cycles. But in the event of excessive pressure or other unexpected conditions, the patented Fail-Dry safety feature provides advance warning... and enables you to prevent a complete valve failure before it occurs. The Plast-O-Matic Fail Dry is the unique concept of having a vented chamber separating two sealed sections of a valve. One of these sections is the fluid media; the other is the spring (operational) chamber. The primary seal – in contact with the fluid media and subject to pressure – will naturally break down before the secondary seal. When the primary seal begins to fail, it releases trace amounts of fluid through the Fail-Dry vent. The secondary seal still isolates the steel spring, so that it remains dry...Fail-Dry!

Fail Dry Relief Valves Remain Fully Operational

...and so does your system. Since the failure can be diagnosed early, valve repair can be performed before a catastrophic failure (such as a seized valve) can occur. Early detection by the Fail Dry reduces the number of parts to be replaced.

Repair Costs are Lower

All valves require maintenance. Although some manufacturers offer a slightly lower initial price, the Fail-Dry prevents the operating springs from being attacked, so that only the elastomers need to be replaced. Most importantly, it's your best protection against dangerous valve-related spills, injuries, and costly downtime.

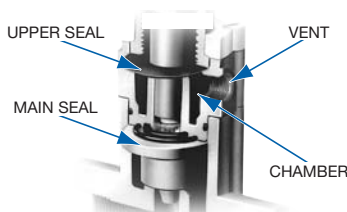

PLAST-O-MATIC VALVES, INC.

1384 Pompton Avenue, Cedar Grove, NJ 07009 USA

(973) 256-3000 • Fax (973) 256-4745

www.plastomatic.com • info@plastomatic.com

AUTHORIZED PLAST-O-MATIC DISTRIBUTOR