



Multi-Voltage Actuator with Fail-Safe and 4-20mA Digital Positioner Options



Standard Features

- Multi-voltage with auto-voltage sensing
 - 12-24V AC or DC
 - 85-240V AC or DC
- LED status light to indicate operational status of actuator
- Electronic over-torque protection against valve jam
- Thermostatic anti-condensation heater
- Manual override for emergency hand operation
- Remote position indicator
- IP65 weatherproof anti-corrosive and UV protected polyamide housing
- Local visual position indicator
- Easy mounting with double-D drive
- All external electrical connections via DIN plugs
- CE marked
- ISO 9000 manufacturer
- Fail-safe and 4-20mA digital positioner options
- Thermally protected motor

The EBVA features a rugged weatherproof and anti-corrosive polyamide housing and more features than the original EBV. A visual indicator shows whether the actuator is operating correctly, or had tripped out either by its electronic torque limiter, or has been left in 'manual' mode. Site operators are no longer left with the 'valve or actuator' question when an actuator does not respond to a signal.

The EBVA is quick and easy to install, with a double-D drive, allowing fast mounting to True-Blue valves. There is no need to remove the cover to connect the EBVA electrically, saving installation time. Using the external DIN plugs and external wiring diagrams supplied with the actuator, installation can be pre-wired.

Protection against valve jams is provided by an electronic torque limiter, which auto-relaxes the gearbox when activated, allowing the manual override to be selected to assist in clearing the jam. The effect of condensation is eliminated by an internal thermostatic anti-condensation heater that does not require a separate independent power supply.

Standard function for the EBVA is power open, power close, stays put on power failure.

New to the EBVA are factory installed Fail-safe and modulating options. The modulating digital positioner offers auto-calibrating and self-resetting functions.



PLAST-O-MATIC VALVES, INC.

1384 Pompton Avenue, Cedar Grove, New Jersey 07009
(973) 256-3000 • Fax (973) 256-4745 • www.plastomatic.com

SPECIFICATIONS

Sizes	3/8" - 2" Valves		2" Full Port through 4"	
	EBVA2, TEBVA6	EBVA1, TEBVA5	EBVA4	EBVA3
Actuator				
Voltage AC (1ph) or DC	12 - 24	85 - 240	12 - 24	85 - 240
Working Time - Sec. 0-90° (No Load) ±10%	11	11	17	17
Maximum Run Torque Nm / in./lbs.	20 / 177	20 / 177	55 / 487	55 / 487
Maximum Break Torque Nm / in./lbs.	25 / 221	25 / 221	60 / 531	60 / 531
On/Off Duty Rating %	75	75	75	75
*Modulating Duty Rating %	100	100	100	100
IP Rating - IEC 60529	IP65	IP65	IP65	IP65
Working Angle Standard	90	90	90	90
Temperature Range (C)	-20° to +70°	-20° to +70°	-20° to +70°	-20° to +70°
Motor Switch	2 x V3	2 x V3	2 x V3	2 x V3
Volt Free End of Travel Confirmation	2 x V3	2 x V3	2 x V3	2 x V3
Anti-Condensation Heater (W)	4	4	4	4
Current Full Load	12VDC 24VDC 24V/1ph 110V/1ph 240V/1ph	1.03A 0.48A 0.98A 0.19A 0.12A	1.96A 0.77A 1.75A	 0.31A 0.19A
Weight (kg)	1.5	1.5	2.0	2.0
ISO:5211	F03,F04 and F05	F03,F04 and F05	F05 and F07	F05 and F07
Drive	Double-D	Double-D	Double-D	Double-D

* Option 3 and 4 only.

EBVA STATUS LIGHT FUNCTIONS



CONSTANTLY LIT LED

If the actuator is operating correctly, with no faults, the LED shows a constantly lit light.



THE LED FLASHES WITH 2 BLINKS

If the actuator has been left in 'manual' mode, the actuators motor runs but doesn't drive the output shaft. After a pre-set time, the actuator knows that as the torque limiter has not activated, and that the motor is running, it must be in manual mode.



THE LED FLASHES ON/OFF

When the actuator senses impending valve jam, the electronic torque limiter is activated and on activation, repeatedly flashes the LED on and off



EBVA OPTIONAL FEATURES

MODULATING ACTUATOR (Option 3 and 4)

Provided via factory installed, self-calibrating digital positioner with 4-20mA or 0-10V.

FAIL-SAFE ACTUATOR (Option 2, 4, or 6)

Fail-safe achieved with the use of industrial re-chargeable batteries which are supplied with the actuator. Specify fail closed or fail open.

APPROXIMATE FLOW RATES AT 1.0 PSI (0,07 Bar) PRESSURE DROP

Valve Sizes	1/2"	3/4"	1"	1 1/4"	1 1/2"	2"	2" Full-Port	2 1/2"	3"	4"
Cv Factor	10	20	40	80	100	120	150	340	485	768

3/8" - 2" SIZES

2" FULL PORT - 4" SIZES

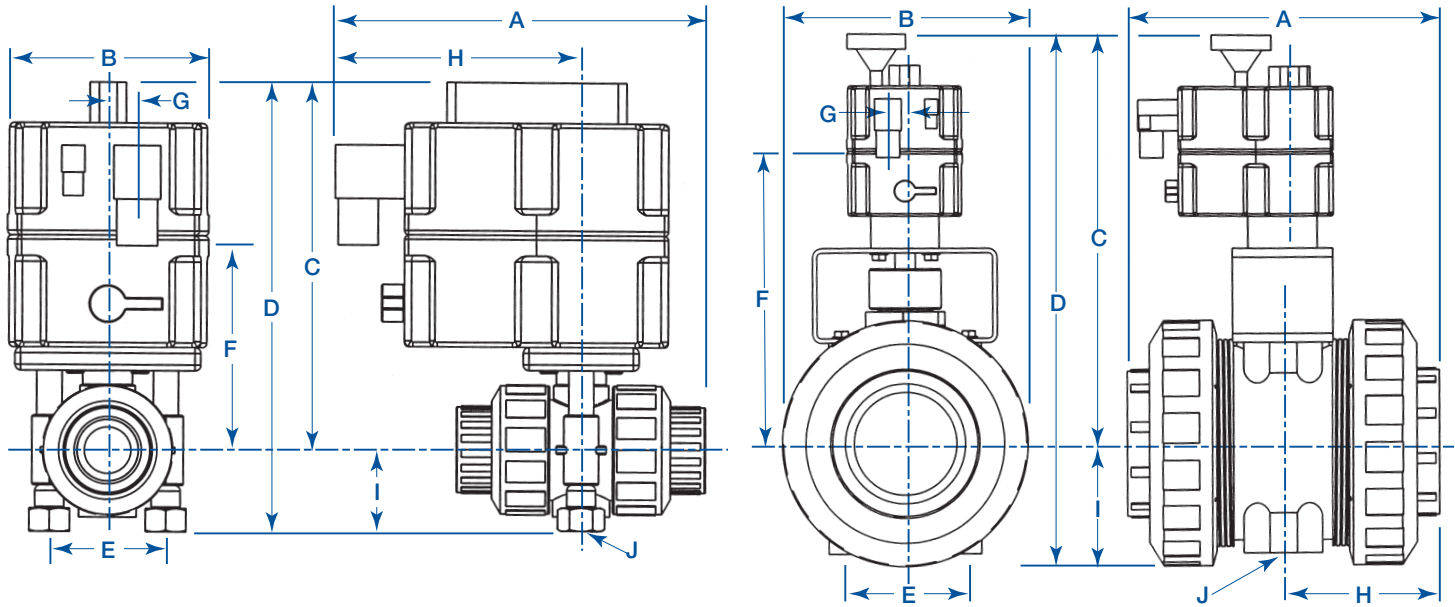

VALVE & ACTUATOR ASSEMBLY – MODEL NUMBERS & DIMENSIONS

Pipe Size	Actuator* with Valve Model No.	A		B		C		D		E		F		G		H		I		J
		IN.	MM	IN.	MM	IN.	MM	IN.	MM	IN.	MM	IN.	MM	IN.	MM	IN.	MM	IN.	MM	IN
3/8"	EBVA-037 -	7 ³ / ₁₆	183	4 ¹¹ / ₃₂	110	7 ³ / ₃₂	180	8 ¹⁹ / ₃₂	219	1 ³ / ₄	45	3 ⁵ / ₈	94	5/8	16	3 ⁷ / ₈	100	1 1/2	38	1/4 - 20
1/2"	EBVA-050 -	7 ³ / ₁₆	183	4 ¹¹ / ₃₂	110	7 ³ / ₃₂	180	8 ¹⁹ / ₃₂	219	1 ³ / ₄	45	3 ⁵ / ₈	94	5/8	16	3 ⁷ / ₈	100	1 1/2	38	1/4 - 20
3/4"	EBVA-075 -	7 ³ / ₁₆	183	4 ¹¹ / ₃₂	110	7 ¹⁷ / ₃₂	188	9 ¹ / ₃₂	229	2 1/4	57	4 1/8	105	5/8	16	3 ⁷ / ₈	100	1 1/2	38	1/4 - 20
1"	EBVA-100 -	7 ³ / ₁₆	183	4 ¹¹ / ₃₂	110	7 ²⁵ / ₃₂	198	9 ¹⁷ / ₃₂	242	2 1/2	64	4 3/8	111	5/8	16	3 ⁷ / ₈	100	1 3/4	45	1/4 - 20
1 1/4"	EBVA-125 -	7 ⁵ / ₁₆	186	4 ¹¹ / ₃₂	111	8 1/4	210	10 ⁹ / ₁₆	269	3 ¹¹ / ₃₂	85	4 7/8	124	5/8	16	3 ⁷ / ₈	100	2 ⁵ / ₁₆	59	1/4 - 20
1 1/2"	EBVA-150 -	7 ⁵ / ₁₆	186	4 ¹¹ / ₃₂	111	8 1/4	210	10 ⁹ / ₁₆	269	3 ¹¹ / ₃₂	85	4 7/8	124	5/8	16	3 ⁷ / ₈	100	2 ⁵ / ₁₆	59	1/4 - 20
2"	EBVA-200 -	7 ⁵ / ₁₆	186	4 ¹¹ / ₃₂	111	8 1/4	210	10 ⁹ / ₁₆	269	3 ¹¹ / ₃₂	85	4 7/8	124	5/8	16	3 ⁷ / ₈	100	2 ⁵ / ₁₆	59	1/4 - 20
2" FP	EBVA-201 -	9 ³ / ₈	206	5 ⁵ / ₁₆	135	9 ¹⁷ / ₃₂	242	11 ²⁹ / ₃₂	303	2 ⁵ / ₈	66	7 ²³ / ₃₂	196	5/8	16	5 ⁵ / ₁₆	135	2 ³ / ₈	60	3/8 - 16
2 1/2"	EBVA-250 -	9 ³ / ₄	247	5 ²⁹ / ₃₂	149	9 ⁷ / ₁₆	239	14 ¹¹ / ₃₂	364	3 ³ / ₃₂	78	9 ⁷ / ₁₆	239	5/8	16	4 ¹¹ / ₃₂	110	3 ³ / ₃₂	78	8MM
3"	EBVA-300 -	10 ¹⁷ / ₃₂	268	7 ³ / ₁₆	183	14 ³ / ₈	365	18 ⁵ / ₃₂	461	2 ¹³ / ₁₆	72	11 ⁷ / ₁₆	290	19/32	15	5 ⁵ / ₁₆	135	3 ²⁵ / ₃₂	96	5/16 - 18
4"	EBVA-400 -	11 ⁹ / ₁₆	293	9 ³ / ₁₆	234	15 ³ / ₁₆	386	19 ⁷ / ₈	502	4 ³ / ₄	121	10 ⁵ / ₈	271	5/8	16	5 ³ / ₄	145	4 ⁵ / ₈	117	8MM

* To complete the Model Numbers refer to the ordering chart below. Voltage must be specified with model number.

ORDERING INFORMATION

Order by part number and specify exact chemicals, temperatures and pressures. To arrive at the proper part number, please consult diagram below. The letters and numbers used in this part number are for example only!

<p>EBVA BASIC MODEL VALVE EBVA 2-Way</p>	<p>1 VALVE TYPE SIZE/VOLTAGE 1 - 2-Way, 3/8"-2", 85-240 Volts, A/C or D/C 2 - 2-Way, 3/8"-2", 12-24 Volts, A/C or D/C 3 - 2-Way, 2 1/2"-4", 85-240 Volts, A/C or D/C 4 - 2-Way, 2 1/2"-4", 12-24 Volts, A/C or D/C</p>	<p>1 OPTIONS 1 - Standard Actuator 2 - Actuator, Fail-Safe 3 - Actuator, 4-20 mA 4 - Actuator, 4-20 mA, Fail-Safe 5 - Actuator, 0-10 VDC 6 - Actuator, 0-10 VDC, Fail-Safe</p>	<p>050 VALVE SIZE 037 - 3/8" 050 - 1/2" 075 - 3/4" 100 - 1" 125 - 1 1/4" 150 - 1 1/2" 200 - 2" 201 - 2" Full Port 250 - 2 1/2" 300 - 3" 400 - 4" 20 - 20mm 25 - 25mm 32 - 32mm 40 - 40mm 50 - 50mm 63 - 63mm 90 - 90mm 110 - 110mm</p>	<p>X SEAL MATERIAL V FKM EP EPDM</p>	<p>T CONNECTIONS S Socket T Thread F Flanges</p>	<p>PV BODY MATERIAL -PV PVC -CP CPVC -PP Natural Polypro -PF PVDF</p>	<p>A BALL OPTIONS A - 3-Hole Ball C - Characterized D - Characterized Descending Curve E - Characterized Ascending Curve Z - Vented Ball</p>
<p>TEBVA 3-Way</p>	<p>5 - 3-Way, 3/8"-2", 85-240 Volts, A/C or D/C 6 - 3-Way, 3/8"-2", 12-24 Volts, A/C or D/C</p>			<p>SPECIAL DESIGNATION — When "X" appears in this spot it designates BSP threads</p>			

AC (1ph) or DC SUPPLY – WIRING FOR MODULATING ACTUATORS

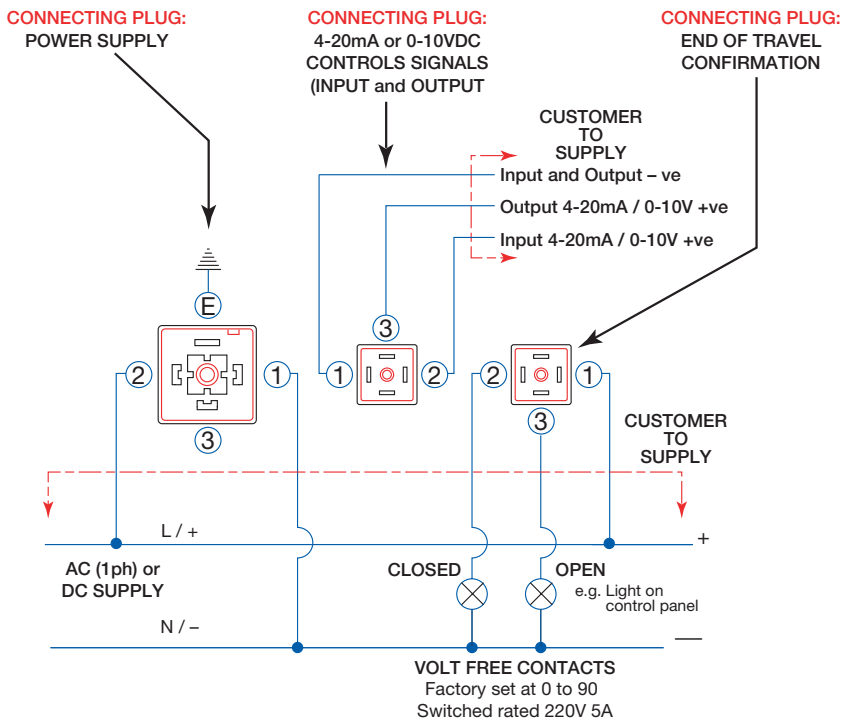

Function: MODULATING VERSION

- Power open, power close – Actuator movement controlled by input signal (4-20mA or 0-10VDC)
- Standard Operation:
4mA or 0V = Actuator Closed,
20mA or 10V = Actuator Open
(can be reversed)
- Standard Operation:
Actuator close on loss of control signal,
stays put if loss on main power.
- Output signal provided as standard
(in same format as supply signal)

NOTE: Wiring showing same supply as motor is only a suggestion, Read *“Installation, Operation and Maintenance Instructions”* before connecting.

⚠ Actuator power supply must be on a dedicated circuit and must be grounded.

AC (1ph) or DC SUPPLY – WIRING ON/OFF OR FAIL SAFE ACTUATORS

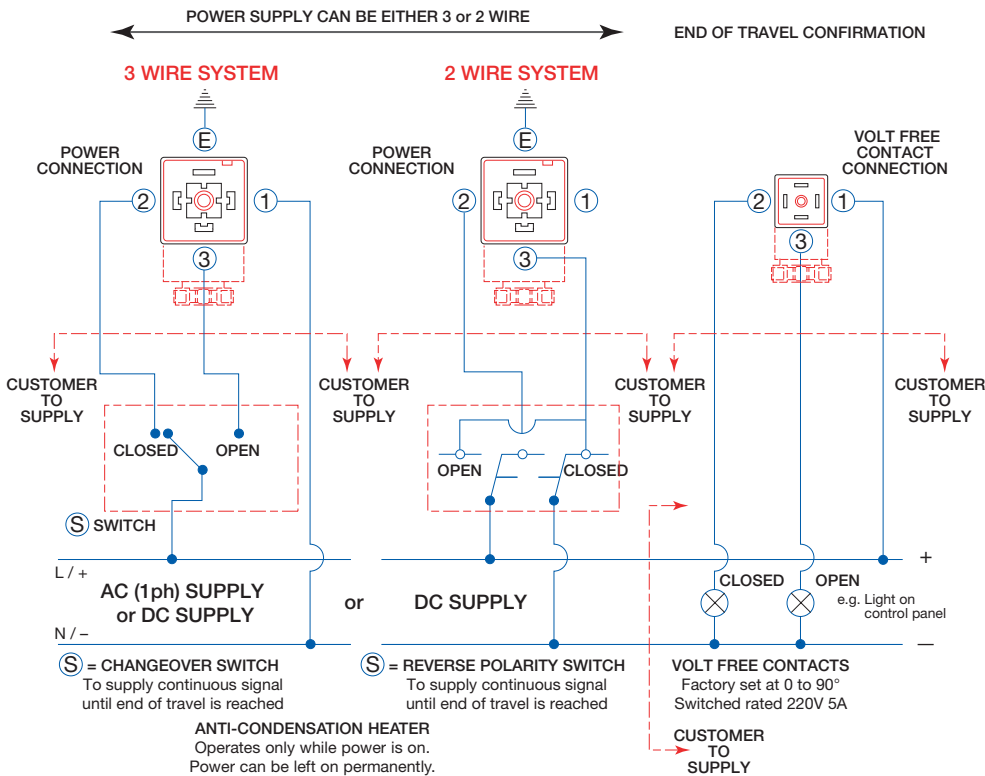

Function: ON/OFF VERSION

- Power open. power close
- Stays on in power failure

Function: FAIL-SAFE VERSION

- Power open, power close – Trickle charges battery in either open or closed position
- Actuator sent by battery power to preset fail safe position on power failure
- Actuator returns to pre-failure position on power resumption
- Fail-safe can be either NC (normally-closed) or NO (normally-open)

NOTE: Wiring showing same supply as motor is only a suggestion, Read *“Installation, Operation and Maintenance Instructions”* before connecting.

⚠ Actuator power supply must be on a dedicated circuit and must be grounded.

⚠ Volt free switches are set approximately 5° ahead of the final motor stop position. Do not use the signal from the volt free switches to cut the power to the motor, otherwise the actuator will not reach the full open or full closed position. The actuator is designed to have continuously energized power.