



Job or Customer: \_\_\_\_\_

Engineer: \_\_\_\_\_

Contractor: \_\_\_\_\_

Submitted by: \_\_\_\_\_ Date \_\_\_\_\_

Approved by: \_\_\_\_\_ Date \_\_\_\_\_

Order No: \_\_\_\_\_ Date \_\_\_\_\_

Specification: \_\_\_\_\_

Installed Date: \_\_\_\_\_

## introduction

IPEX's **Labline™** mechanical-joint system is the preferred solution for virtually all non return air plenum chemical waste applications. Pipe and fittings are made from flame retardant Polypropylene (FRPP). A non-flame retardant Polypropylene is also available upon request (NFRPP). **Labline™** FRPP and NFRPP pipe and fittings comply with ASTM F1412 Standard specification for Polyolefin pipe and fittings for corrosive waste drainage systems. Material used in the manufacturing of **Labline™** FRPP and NFRPP pipe and fittings complies with the material requirements of ASTM D4101. Standard Specification for polypropylene for Injection and Extrusion materials. All pipe and fittings are listed to NSF 14 standard and IAPMO.

### < STANDARDS >



ASTM F1412  
ASTM D 4101  
ASTM D 635



NSF 14



File No:  
1103, 3455

### ADDITIONAL CORROSIVE WASTE PRODUCTS

#### FLOWAY™

ACID RESISTANT FLOOR DRAINS

#### NEUTRATANK®

NEUTRALIZATION TANKS

#### NEUTRASYSTEM2™

MONITORING, RECORDING & ALARM SYSTEMS

#### PLENUMLINE™

FR-PVDF MECHANICAL JOINT ACID WASTE SYSTEM

#### ENFIELD®

ELECTROFUSION ACID WASTE SYSTEM

#### Encase™

PP Double Containment System

## pipe and fitting availability

1 1/2" - 12" Pipe (10' or 20' FRPP Sch. 40 & 20' NFRPP Sch. 80)	1 1/2" - 12" 45 Deg Wye and Reducing WYES FRPP
1 1/2"- 4" Couplings And Reducer Couplings FRPP	11/2" - 4" Double Wye, Reducing Double Wye FRPP
1 1/2"- 4" 1/4 Bend, Loose Nut 1/4 Bend FRPP	1 1/2" x 1 1/4" Threaded Adapter 1 1/2" x 1 1/2" FRPP
1 1/2"- 4" Cleanout Plug FRPP	1 1/2"- 4" Caps FRPP
1 1/2" Tailpiece Adaptor, (3" & 12" Lengths) FRPP	1 1/2"- 2" "U" Bend, "S" Trap, Running Trap FRPP
1/2" - 4" 1/8 Bend , Loose Nut 1/8 Bend FRPP	1 1/2"- 4" 'P' Trap, Long Radius 'P' Trap FRPP
Sink Outlet With Plug	1 1/2" - 4" Male Adaptor FRPP
Cup Sink Round / Oval	1 1/2" - 2" Female Adaptor FRPP
1 1/2"- 4" Sanitary Tees, Reducing Sanitary Tees, Clean Out Tees FRPP	1 1/2"- 4" Grooving Tool And Spanner Combinations (Also Sold Separately)
1 1/2"- 4" Glass Adaptor, No Hub Adapter FRPP	1 1/2" Universal Traps (Various) "S" Type Universal Traps (Various) , Dilution Traps FRPP
1 1/2"- 4" Combo Wyes And Reducing Combo Wyes FRPP	11/2" - 4" Double Wye & 1/8 Bend, Reducing Double Wye & 1/8 Bend

## Installation Procedures

### Points to Remember

- a. **NEW YELLOW ELASTOLIVE DOES NOT REQUIRE PRE-HEATING.**  
(If heated, maximum temperature should not exceed 175°F.)
- b. The pipe end should be clean and there should be no deep longitudinal grooves in it.
- c. It is desirable to use a chain vise to hold 3" and 4" pipe firmly during cutting and grooving operations. When grooving 3" and 4" pipe, a strap wrench should be used to hold the pipe, to prevent its rotation, while the groove is being cut.
- d. After grooving, the pipe should be kept clean so that foreign material is not introduced into the groove.
- e. The cutting blade should always be fully retracted whenever the tool is put on or taken off the pipe. If any resistance is felt when putting the tool onto the pipe or taking it off, the blade position should be checked.
- f. Each nut must be fully tightened as the installation progresses. Do not assemble the system loosely and tighten nuts last, as layout length errors will go undiscovered until such time as the nuts are finally tightened. Avoid misalignment.
- g. Ensure the grooving tool has a sharp blade to make a clean-shouldered groove.

### Procedure:

1. Each fitting is supplied with the correct number of yellow elastolive® (sealing rings) and nuts.
2. Verify the grooving tool is sharp. Cut the pipe to the desired length using a tubing cutter fitted with a wheel designed for plastic pipe. A handsaw and miter box may also be used. **Ensure pipe ends are square and trimmed free of burrs.**
3. Examine the grooving tool to ensure that the cutting blade is fully retracted. Insert the pipe into the grooving tool.
4. Set the grooving blade at the half-depth position and rotate the tool in a counter-clockwise direction. After one complete turn, set the blade at the full-depth position and again rotate the tool one full turn counter-clockwise. Fully retract the blade and remove the tool from the pipe. A shallow groove has now been formed around the pipe.

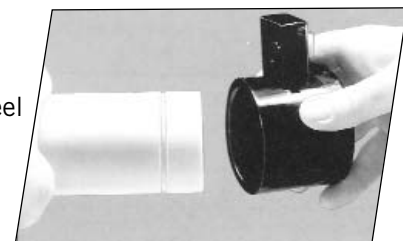

Any material left as a feather edge in the groove should be removed. Care should be taken not to damage the square edge (shoulder) of the groove, particularly at the edge near the spigot end of the pipe as this is the primary sealing surface. Feathered or rounded edges, may indicate a worn tool and may result in possible leakage. Make sure the grooved shoulders are sharp.

GROOVING TOOL BLADE POSITIONING



## 3" and 4" Labline Joint Details

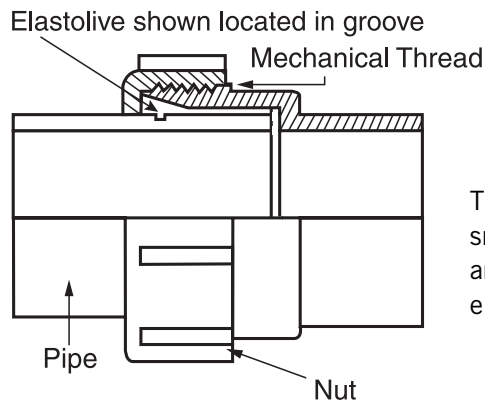

The 3" and 4" joint design differ from smaller versions in that the sealing ridges are located on the fitting and the elastolive extends to the end of the pipe.

## 1½" and 2" Labline Joint Details

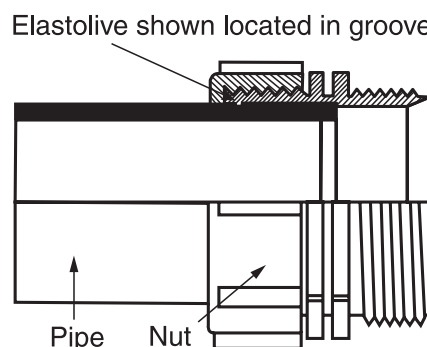

Once engaged in the groove, the elastolive virtually becomes part of the pipe and when the nut is tightened, the pipe is locked into the fitting.

5. Place the nut onto the pipe with the threaded side to the spigot end of the pipe. Take the yellow elastolive, stretch it and pull it over the pipe with the thick edge first and the taper pointing to the spigot end of the pipe. Slide down the pipe and onto the groove. Once on the groove "work it" a bit to make sure that the rib on the underside of the elastolive engages the full circumference of the groove.
6. Apply a non-hydrocarbon based lubricant to both the thread and the elastolive, then push the pipe squarely into the fitting.

The lubrication permits easy threading of the nuts and also allows the elastolive to glide smoothly into position against the fitting sealing area. Hand-tighten the nut, then tighten, 1/4 to 1/2 turn using a spanner wrench.

7. The joint is now ready for testing.

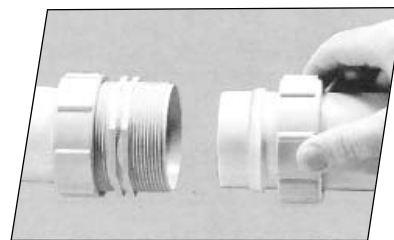

# Hydrostatic Testing Procedures



## WARNING

Use of compressed air or gas in PVC/CPVC/PP/PVDF pipe and fittings can result in explosive failures and cause severe injury or death.

- **NEVER** use compressed air or gas in Enfield or Labline pipes, fittings, or accessories.
- **NEVER** test Enfield or Labline systems with compressed air or gas, or air-over-water boosters.
- **ONLY** use Enfield or Labline systems for water and approved chemicals.



### Hydrostatic Testing Procedures

The purpose of a site pressure test is to establish that all joints have been correctly made. Hydro test in accordance with local plumbing code or with authority having jurisdiction or with a maximum of 10 ft of head pressure. After making the first 20 or 30 joints, it is recommended that a test be applied to prove that the joint-making technique is satisfactory. If a leak is discovered, follow the appropriate procedure below. Hydrostatic testing of the joints can be performed immediately after the final joint has been completed. The low pressure testing procedure detailed below should be strictly followed.

1. Fully inspect the installed piping for evidence of mechanical abuse and suspect joints.
2. Split the system into convenient test sections, not exceeding 1,000 feet. The piping should be capped off with an expandable plug at the end of the pipe section to be tested.
3. Prior to test in below grade applications, straight lengths of pipe should be backfilled between fittings that are tested.
4. Slowly fill the pipe section with water, taking care to evaluate all trapped air in the process. Use air release valves in any high spots in the system. Do not pressurize at this stage.
5. Leave the pipe for at least one hour to allow an equilibrium temperature to be achieved.
6. Visually check the system for leaks.
7. Pressurize the system, (maximum of 10 feet of head) using a 10' vertical riser, or a low-pressure hand pump.
8. Leave the line at 10 feet of head for a period of 2 hours, during which time the water level should not change (standing water test), nor should the pressure gauge reading change (hand pump test).

## *Hydrostatic Testing Procedures*

9. If there is a significant drop in pressure, or extended times are required to achieve the desired pressure, either joint leakage has occurred or air is still entrapped in the line. In this event inspect for joint leaks. If none are found, check for entrapped air – these air pockets must be removed prior to continuing the test.
10. If joints are leaking, tighten the nut 1/8 to 1/4 turn and wipe the fitting to remove excess water. This should normally correct the problem. If it does not, then the grooving or setting of the elastolive should be investigated. Drain the system and undo the suspect fitting. Test first that the elastolive feels tight on the pipe by attempting to turn it with reasonable pressure such as you might use to unscrew the cap of a bottle. The elastolive should not easily move around the pipe. If it does, it should be replaced. If the elastolive is tight, examine it, particularly at the front, for signs of bad grooving or shavings between the elastolive and the groove. If the front edge of the groove is damaged, the joint must be re-made and the piece of pipe replaced. When examining a leaking 3" or 4" joint, particular attention should be paid to possible misalignment, as this is the most likely cause of such a leak. Make sure any misalignment is corrected before re-testing.
11. Repeat the 10 feet of head test after repairing any leaking joints, following the procedure described above.

## Material Properties

Properties	Materials	
	Valve	Standards
Specific Gravity	0.94	D1505
Tensile Yield Strength @ 2"/Min.	4400 psi	D638
Flexural Modulus	215,000 psi	D790
Hardness, Rockwell R	100	D1706
Izod Impact, Notched	1.0 ft. lbs/in.	D256
Coefficient of Linear Expansion	$6 \times 10^{-5}$ in/in/F	D696
Heat Deflection Temperature @ 66 psi load	220 – 240°F	D648
Heat Deflection Temperature @ 264 psi load	195°F	D648
Water Absorption. 24 hrs.	0.01%	D570
* Time of Burning (sec.)	< 5	D635
* Extent of Burning (mm)	< 5	
* Burning Class	V2	UL94
* Maximum Smoke Density	62.0	D2843
* Smoke Density Rating	40.1	
* Oxygen Index %	28	D2863

\* All burning properties apply to FRPP pipe and fittings only.

