

GUARDIAN DOUBLE CONTAINMENT

Submittal Data Sheet



Job or Customer:

Engineer:

Contractor:

Submitted by: Date

Approved by: Date

Order No: Date

Specification:

introduction

Guardian systems offer a complete selection of pretested modular components which are extremely easy to install. Our Centra-lok™ patented design allows IPEX to offer vinyl systems which average up to 60% fewer overall joints and up to 10% fewer field joints. Since joints are always the most common source of premature failures and leaks, it is easy to realize the immense impact the Centra-lok design has on maintenance, repair and installation costs. The patented ingenuity and simplicity of the Centra-lok design also reduces the purchase cost of IPEX systems, making Guardian the industry's most cost-effective vinyl system.

As with all our containment systems, the IPEX patented Centra-Guard™ point-of-collection or cable leak detection systems are also available.

COMPANION PRODUCTS



CARRIER MATERIAL CONTAINMENT MATERIAL

- | | | | |
|------|--------------------------|------|--------------------------|
| PVC | <input type="checkbox"/> | PVC | <input type="checkbox"/> |
| CPVC | <input type="checkbox"/> | CPVC | <input type="checkbox"/> |

CARRIER SIZE CONTAINMENT SIZE

- | | | | | |
|--------|--------------------------|---|-----|--------------------------|
| 1/2" | <input type="checkbox"/> | X | 2" | <input type="checkbox"/> |
| 3/4" | <input type="checkbox"/> | X | 3" | <input type="checkbox"/> |
| 1" | <input type="checkbox"/> | X | 3" | <input type="checkbox"/> |
| 1 1/2" | <input type="checkbox"/> | X | 4" | <input type="checkbox"/> |
| 2" | <input type="checkbox"/> | X | 4" | <input type="checkbox"/> |
| 3" | <input type="checkbox"/> | X | 6" | <input type="checkbox"/> |
| 4" | <input type="checkbox"/> | X | 8" | <input type="checkbox"/> |
| 6" | <input type="checkbox"/> | X | 10" | <input type="checkbox"/> |
| 8" | <input type="checkbox"/> | X | 12" | <input type="checkbox"/> |

pipe and fitting availability

PIPE

The pressure rated system is available in any combination of Vinyl by Vinyl and comes in a size range of 1/2" x 2" to 8" x 12" (Containment x Carrier) in Sch 40 or Sch 80.

A DWV system is also available in PVC by PVC and comes in a size range of 1 1/2" x 4" to 8" x 12" (Containment x Carrier).

FITTINGS

PRESSURE SYSTEM	DWV
Tee	90° elbow
90° Elbow	Sanitary Tee
45° Elbow	Wye
	Wye with 1/8 bend
	P Trap
	Reducer / Increaser
	Cleanout Floor Drain

PVC and CPVC termination fittings are available in sizes ranging from 1/2" x 2" to 4" x 8" (Carrier x Containment)



GUARDIAN DOUBLE CONTAINMENT

Installation Procedures

Installation

PVC and CPVC



1. Square cut pipe using a saw and miter box or plastic tube cutter. Remove all burrs from both the inside and outside edge of the pipe with a knife, file or reamer bevel all ends. Remove dirt, grease and moisture. A thorough wipe with a clean, dry rag is usually sufficient. Check dry fit. Pipe should insert easily into socket, approximately 1/4 to 3/4 of the total socket depth.
2. Using a suitable applicator, apply an approved primer to the socket of the fitting. (Care should be taken not to allow primer to puddle in fitting socket.) Next, apply primer to pipe surface equal to the depth of the fitting socket. Apply primer again to fitting socket. (Primer is used to soften the surfaces of pipe and fitting, making them suitable for solvent cementing.) Continue to next step immediately.
3. With the same type of applicator, apply a full, even coat of an approved solvent cement to the pipe equal to the depth of the fitting socket. Coat the fitting socket with a medium layer of cement. (Care should be taken not to allow cement to puddle in fitting socket). Apply a second, full, even layer to the pipe. Cement must be applied in sufficient quantities to fill the joint.
4. Without delay assemble while cement is still wet. Use sufficient force to ensure that pipe bottoms in socket. If possible, twist the pipe or fitting 1/8 to 1/4 turn as assembled.

Hold together for about thirty seconds to make sure joint does not separate. With a rag, wipe off excess cement. Avoid disturbing the joint.

Simultaneous Solvent Cementing

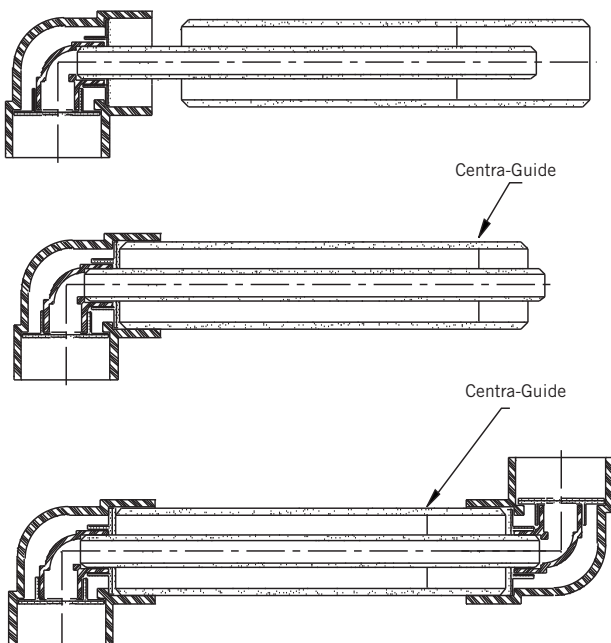

1. Determine proper carrier and containment pipe lengths to achieve desired center-to-center dimension. Cut to size and prep ends.
2. Prime and solvent cement carrier pipe to carrier fitting socket.
3. Prime and solvent cement containment pipe to containment socket.
4. Install Centra-guide support at pipe's end. Distance between the fitting and support should not exceed 5 feet. Install additional supports if required.
5. Dry-fit fitting to pipe end to ensure proper fit and alignment. Mark containment pipe to ensure full insertion during simultaneous solvent cementing.
6. Apply primer and solvent cement to carrier and containment hubs and pipe ends. Position fitting onto pipe ends, making sure fitting bottoms out completely.

GUARDIAN DOUBLE CONTAINMENT

Installation Procedures

Single Closure Coupling Method

1. Determine proper carrier and containment length to achieve desired center-to-center dimension. Cut carrier pipe to size and prep ends. For single closure coupling installations, the containment pipe is cut into 2 pieces. Piece #1 is equal to 2 x containment socket depth. Piece #2 is equal to the predetermined containment pipe length less the overall length of piece #1 plus 1". See example.

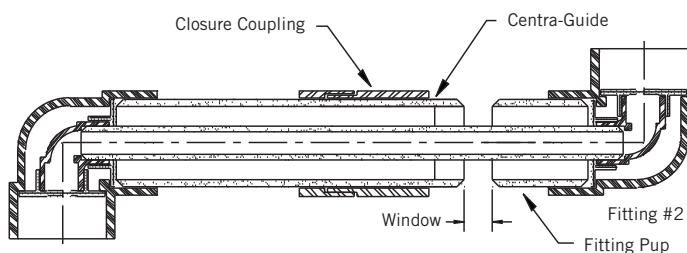
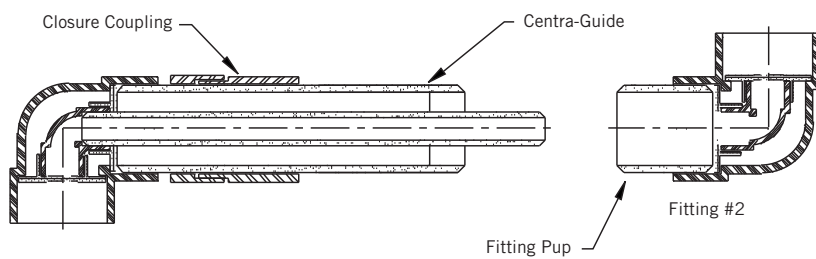
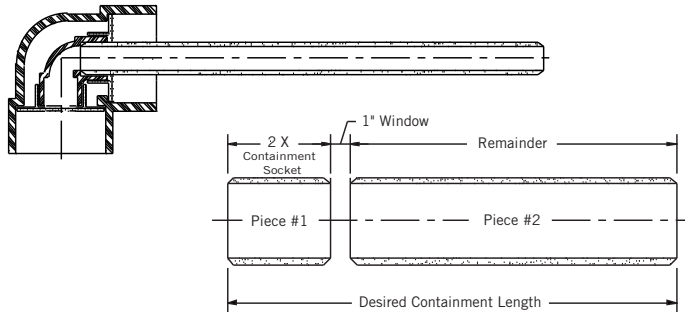

2. Prime and solvent cement piece #2 into fitting. Install support(s) as required. Slide closure coupling onto clean, dry containment pipe, making sure coupling is installed in proper direction. (Take appropriate precautions to ensure closure coupling is kept free of dirt and moisture prior to closure coupling installation. i.e. wrap with plastic or tape ends.) Prime and solvent cement fitting pup into socket of fitting #2.

3. Prime and solvent cement carrier pipe to fitting #2. If containment pipe was cut properly, there should be a 1" window between containment pipe pieces. After successfully testing carrier pipe, install closure coupling per instructions.

Note: IPEX recommends that vinyl/vinyl systems be installed without closure couplings whenever possible.

GUARDIAN DOUBLE CONTAINMENT

Installation Procedures

Termination Fittings

Style A

Install containment pipe socket flange using standard procedure. Always bevel carrier pipe end or damage to the o-rings will occur. The blind flange can be ordered with taps to allow for venting, draining, etc.

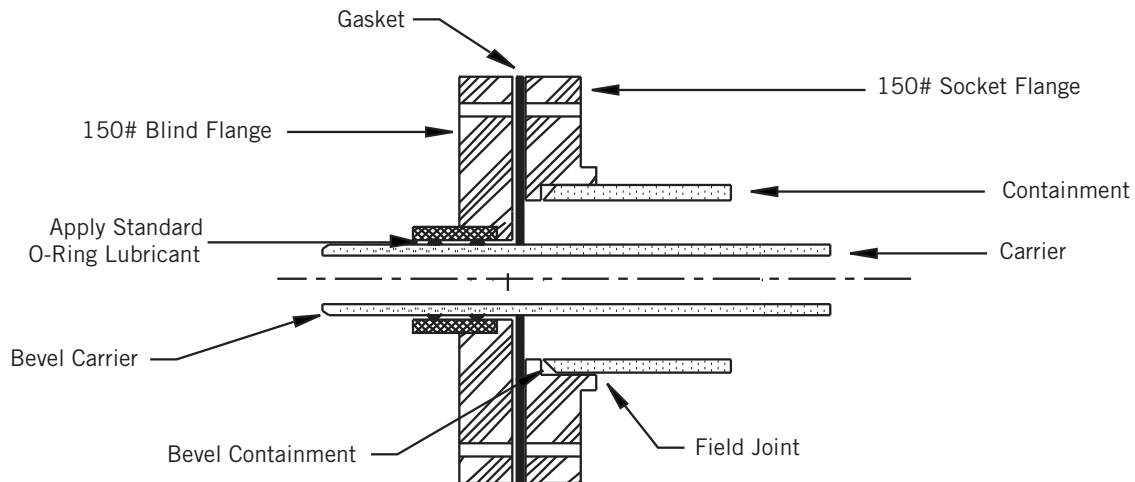

Style B

PVC and CPVC termination fittings are supplied as one-piece components, complete with carrier pipe o-rings. Always bevel carrier pipe end or damage to the o-rings will occur. Prime both the containment pipe and socket of termination fitting. Apply cement to both containment pipe and termination socket and slide into position, rotating 1/8 to 1/4 turn. Allow 24 hours cure time prior to testing. The fitting can be ordered with taps to allow for venting, draining, etc. Do not apply primer or solvent cement to o-rings.

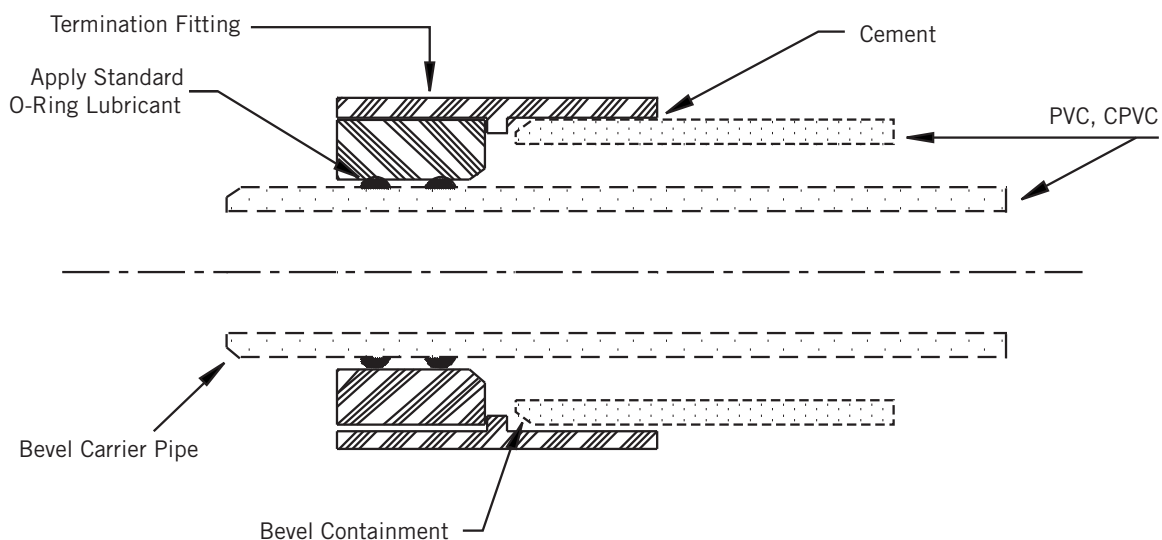

GUARDIAN DOUBLE CONTAINMENT

Installation Procedures

Closure Coupling

1. Thermally equalize both the pipe and closure coupling by exposing them to similar temperatures for over 60 minutes. Clean containment pipe with a clean cloth prior to sliding closure coupling onto pipe with minimum resistance. If coupling does not respond accordingly, contact factory. Wrap the coupling with a waterproof plastic bag, or wrap with tape while on containment pipe to keep it clean and dry prior to solvent cementing.

Note: Always use an approved primer and a “medium body – slow set” cement for all cementing procedures on PVC. Check expiration date on cement. If cement exceeds the date, throw away and use cement by expiry date.

2. Bevel all ends of pipe. Slide the closure coupling across the pipe window to check for proper alignment. If resistance is met when transitioning from one side to the other, reposition containment pipe to eliminate resistance.

Note: All closure coupling installations require two people

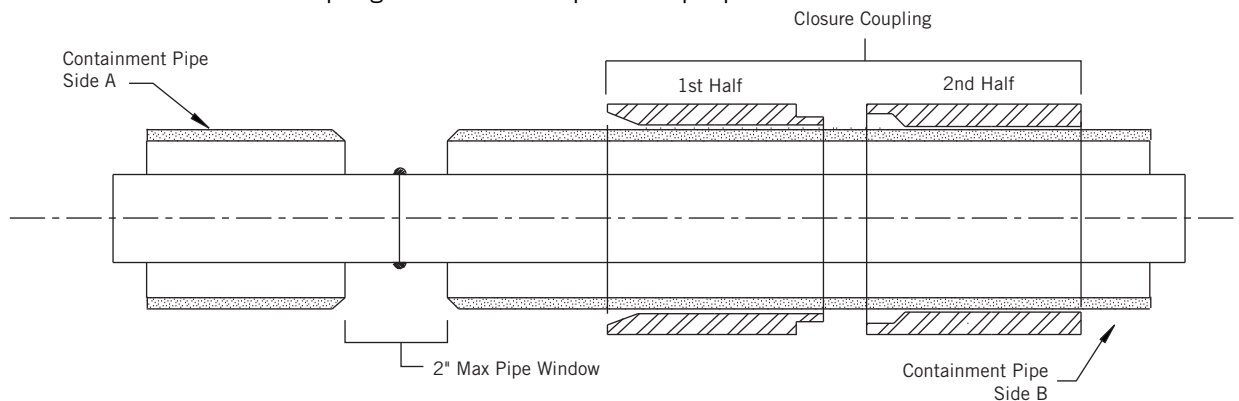

3. Liberally apply primer to 'Side A' of containment pipe as indicated above. Quickly slide the first half of the closure coupling onto the pipe (rotating constantly). Slide closure coupling back to Side B. Do not stop rotating. Apply more primer to Side A and repeat. Perform the same procedure with solvent cement and position first half on Side A as shown below.

Note: Restrain the first half of closure coupling so it doesn't move from its position while cementing the second half of the closure coupling.

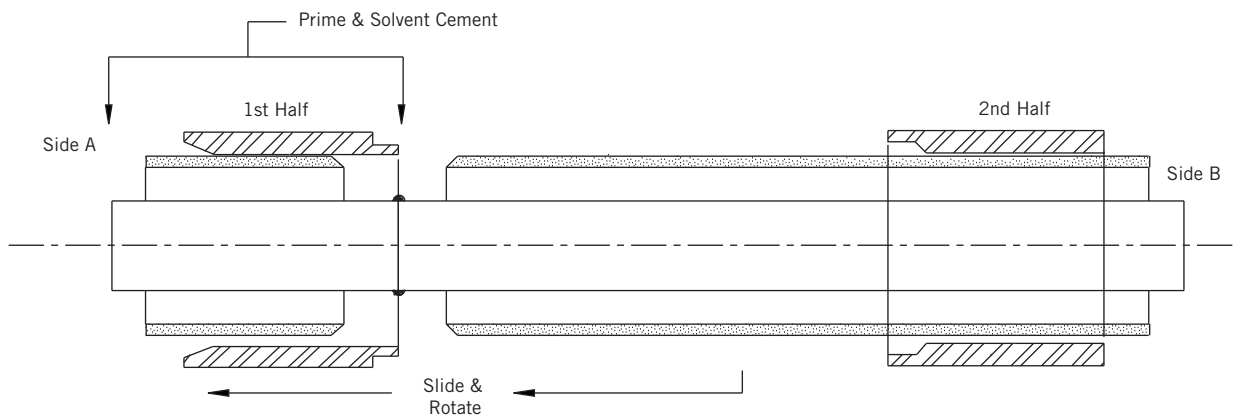

GUARDIAN DOUBLE CONTAINMENT

Installation Procedures

- Repeat the previous step with the second half of the closure coupling on Side B and place into position as shown below.

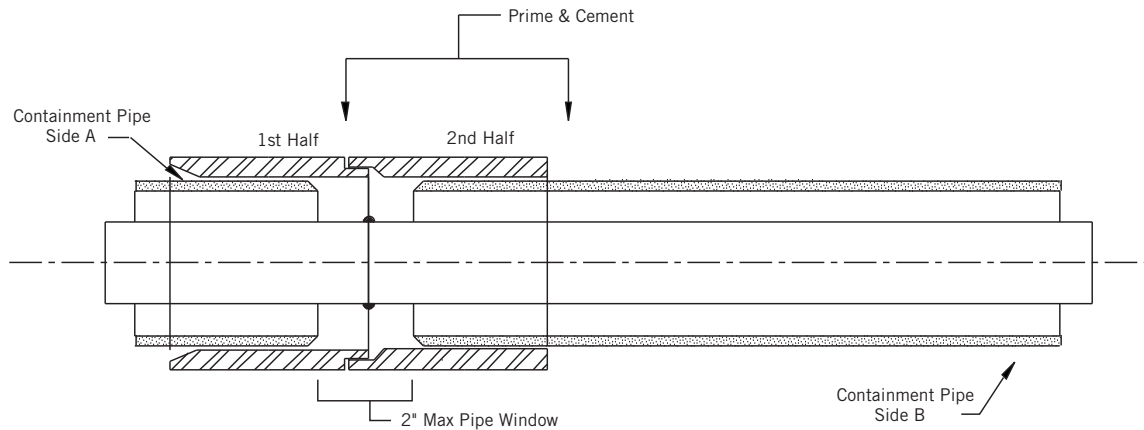

- If the containment pipe will see temperature changes during the curing process or while in operation, shear pins need to be installed. Using a 3/8" bit, drill holes through the closure coupling and containment pipe as shown above. Use caution while drilling to prevent any damage to the carrier pipe. Apply primer and solvent cement to the shear pins (provided with the closure coupling) and insert into hole. Allow 24 to 48 hours cure time before pressure testing.

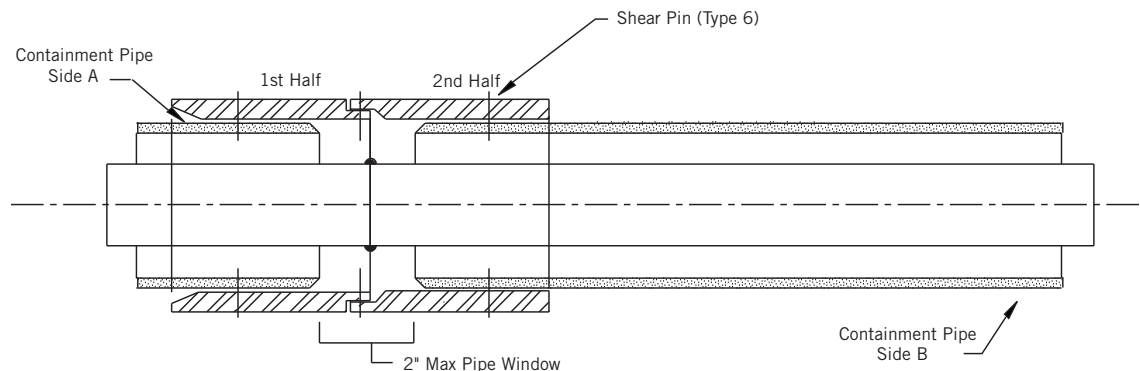

GUARDIAN DOUBLE CONTAINMENT

Installation Procedures

2" and 3" Closure Couplings

The procedure for installing 2" and 3" closure couplings is the same as 4" and above, except that the design is slightly different. The 2" and 3" closure couplings have a female socket on the trailing edge of the first half piece and a male end on the leading edge of the second half. Also, the first half piece is much longer than the second half piece. This means that the trailing edge of the first half piece will rest on 'Side B' of the containment pipe as opposed to being in the 2" window (see drawing below).

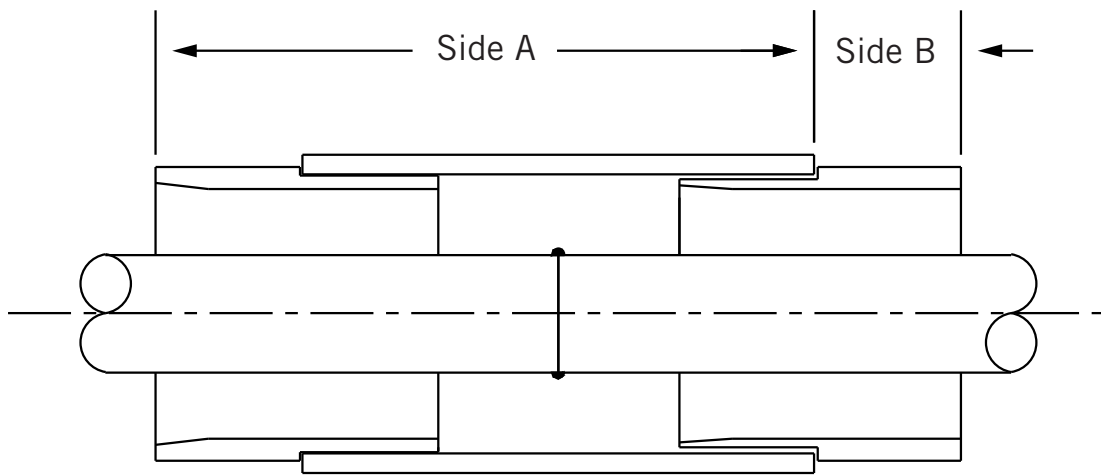

Cleaning and Testing

Upon completing installation, the primary piping system shall be hydrostatically tested at 150% of the system design pressure for a period of one hour. Additionally, the system may be tested during the installation at intervals to be determined by the manufacturer (IPEX).

If Secondary pipe cannot be hydro-tested, as determined by the engineer or authority having jurisdiction, then the use of nitrogen or air at a MAXIMUM 5 psi (gauge) shall be allowed. The external joint should be visually inspected for leaks using an IPEX approved leak detector.

Both the preliminary and final tests shall be performed in strict accordance with the recommendations of the manufacturer (IPEX) including the sequence and duration of such tests.



WARNING

It is imperative that a working-pressure regulator be used during the pneumatic test to ensure that over-pressurization of the PVC, beyond 5 psi, cannot occur. The following must also be noted: Air or nitrogen under pressure is compressed and therefore poses a potential hazard. If a failure of the pipe or fitting occurs during such test, the air exits at the failure point and expands rapidly.

This increase in velocity can cause the system to fail in a catastrophic mode.

Therefore during such air test all personnel involved in the test or present in the test surrounding area must be aware of such a possibility and take all necessary precautions.

Precautions include, but are not limited to, taking extreme care not to impact or damage the system in any way. Such procedure is a limited exception to IPEX standard policy which forbids the use of its rigid systems with any compressed gases, unless the product(s) is specifically designed for the conveyance of compressed gases.



GUARDIAN DOUBLE CONTAINMENT

Materials and Specifications

The double containment piping system shall be a Guardian prefabricated system as manufactured by IPEX. The system shall be fabricated, installed and tested in accordance with IPEX's recommendations and as specified herein and shall be suitable for the intended service. Manufacturer shall have a minimum of five (5) years experience. Contractor shall not design and/or fabricate the piping system.

PVC Double Containment Piping System

Materials

The primary pipe and fittings shall be manufactured from Xirtec 140 DWV, schedule 40, or schedule 80 PVC materials as manufactured by IPEX and as listed by ASTM and ANSI.

The secondary containment pipe and fittings shall be manufactured from Xirtec 140 DWV, schedule 40, or schedule 80 PVC materials as manufactured by IPEX And as listed by ASTM and ANSI.

All listed primary pipe shall be shall be Xirtec 140 DWV, schedule 40 or schedule 80 materials. Pipe shall have DWV thickness according to ASTM D-2665, schedule 40 thickness according to ASTM D-1785, or schedule 80 thickness according to ASTM D-1785. All listed primary pressure fittings shall be schedule 40 PVC according to ASTM D-2466, or schedule 80 PVC according to ASTM D-2467 specifications. All other unlisted components intended for use as pressure retaining components shall have sufficient thickness and reinforcement so as to be able to maintain the same pressure ratings as the equivalent DWV or schedule PVC pipe. Interstitial supporting devices used to center and support the primary piping within the secondary containment piping shall be manufactured from Polypropylene Centra-Guide supports, according to ASTM and ANSI.

All listed secondary containment pipe and fittings shall be IPEX's Xirtec 140 DWV, schedule 40, or schedule 80 materials as manufactured by IPEX. Pipe shall have DWV thickness according to ASTM D-2665, schedule 40 thickness according to ASTM D-1784, or schedule 80 thickness according to ASTM D-1784. All listed pressure fittings shall be schedule 40 according to ASTM D-2466 or schedule 80 according to ASTM D-2467. All other unlisted components intended for use as pressure retaining components shall have sufficient thickness and reinforcement so as to be able to maintain the same pressure ratings as the equivalent DWV or schedule PVC pipe.

All fittings will be pre-assembled (1/2" through 4" carrier fittings will be supported with the Centra-Lok [U.S. Patent No. 5,398,973] system, 6" and larger carrier will be supported with IPEX standard Polypropylene fitting discs) and pre-tested by the manufacturer (IPEX).

GUARDIAN DOUBLE CONTAINMENT

Materials and Specifications

CPVC Double Containment Piping System

Materials

The primary pipe and fittings shall be manufactured from Corzan schedule 80 CPVC materials as manufactured by IPEX and as listed by ASTM and ANSI.

The secondary containment pipe and fittings shall be manufactured from Corzan schedule 40 or schedule 80 CPVC materials as manufactured by IPEX. And as listed by ASTM and ANSI.

All listed primary pipe shall be shall be Corzan schedule 80 materials. Pipe shall have schedule 40 or schedule 80 thickness according to ASTM F-441 All listed primary pressure fittings shall be schedule 80 CPVC according to ASTM F-439 specifications. All other unlisted components intended for use as pressure retaining components shall have sufficient thickness and reinforcement so as to be able to maintain the same pressure ratings as the equivalent schedule 80 CPVC pipe.

Interstitial supporting devices used to center and support the primary piping within the secondary containment piping shall be manufactured from Polypropylene Centra-Guide supports, according to ASTM and ANSI.

All listed secondary containment pipe and fittings shall be IPEX's Corzan schedule 40, or schedule 80 materials as manufactured by IPEX. Pipe shall have schedule 40 or schedule 80 thickness according to ASTM F-441. All listed pressure fittings shall be schedule 80 according to ASTM F-439. All other unlisted components intended for use as pressure retaining components shall have sufficient thickness and reinforcement so as to be able to maintain the same pressure ratings as the equivalent schedule CPVC pipe.

All fittings will be pre-assembled (1/2" through 4" carrier fittings will be supported with the Centra-Lok [U.S. Patent No. 5,398,973] system, 6" and larger carrier will be supported with IPEX standard Polypropylene fitting discs) and pre-tested by the manufacturer (IPEX).

GUARDIAN DOUBLE CONTAINMENT

Specifications

PROPERTIES	MATERIALS			Standards
	PVC	CPVC (Standard)	CPVC (High Impact)	
Cell classification	12454	23447	24448	
Specific gravity	1.42	1.50	1.51	ASTM D 792
Tensile strength, psi at 73°F	7,000	7,500	7,320	ASTM D 638
Modulus of elasticity tensile, psi at 73°F	400,000	380,000	360,000	ASTM D 638
Flexural strength, psi	14,500	11,400	13,200	ASTM D 790
Izod impact, ft.lbs./in. at 73°F, notched	0.65	2.0	10.0	ASTM D 256
Compressive strength, psi	9,000	10,100	10,100	ASTM D 695
Poisson's ratio	0.38	0.33	0.33	
Working stress, psi at 73°F	2,000	2,000	2,000	
Coefficient of thermal expansion in./in./°F (x 10 ⁻⁵)	3.0	3.8	3.4	ASTM D 696
Linear expansion, in./10°F per 100' of pipe	0.36	0.44 - 0.46	0.41	
Maximum operating temperature under pressure	140°F (60°C)	200°F (93°C)	200°F (93°C)	
Deflection temperature under load, °F at 66 psi	173	n/a	n/a	ASTM D 648
Deflection temperature under load, °F at 264 psi	160	212	239	ASTM D 648
Thermal conductivity, BTU.in./hr.ft ² .°F	1.2	0.95	0.95	ASTM C177
Burning rate	Self extinguish	Self extinguish	Self extinguish	ASTM D 635
Burning class	V-0	V-0	V-0	UL-94
Flash ignition, °F	730	900	900	
Limited oxygen index (%)	43	60	60	ASTM D 2863-70
Water absorption, %, (24 hrs. at 73°F)	0.05	0.03	0.03	ASTM D 570

* The properties listed in this table represent general material properties and should be used as a guideline only.

