

True Union Ball Check Valve

Specifications

Sizes: True Union : 1/2" - 2"
Single Union: 3" - 4"

Models: Socket, Threaded, Flanged (ANSI), Butt End

Bodies: PVC, CPVC, PP and PVDF

Seats: EPDM, FKM, PTFE

Seals: EPDM, FKM, PTFE

Option: Foot Valve

Sizes 1/2" - 4" PVC/EPDM/FKM Models are available with NSF-61 Certification

Standard Features (Sizes 1/2" - 2")

- Uniseat/seal of EPDM or FKM
- Ball is the only moving part. It unseats to permit flow in one direction but seals against seat to prevent backflow.
- May be used vertically or horizontally
- Minimum shut-off of 5 psi
- All sizes rated for full vacuum service
- Solid thermoplastic ball

Options:

- PTFE coated FKM uniseat/seal
- Spring-loaded ball to assist ball in seating faster

Parts List - True Union (Sizes 1/2" - 2")

PARTS			
NO.	DESCRIPTION	PCS.	MATERIAL
1	Body	1	PVC, CPVC, PP, PVDF
2	Ball	1	PVC, CPVC, PP, PVDF
3	End Connector	2	PVC, CPVC, PP, PVDF
4	Union Nut	2	PVC, CPVC, PP, PVDF
5	Stop Ring (A)	1	PVC, CPVC, PP, PVDF
8	Stop Ring (B)*	1	PVDF
9	Seat	1	EPDM, FKM, PTFE
10	O-Ring	1	EPDM, FKM, PTFE
3a	Ring**	1	Stainless Steel 304

* Used for flanged end

** Used for CPVC body, threaded end; 1/2" - 1"

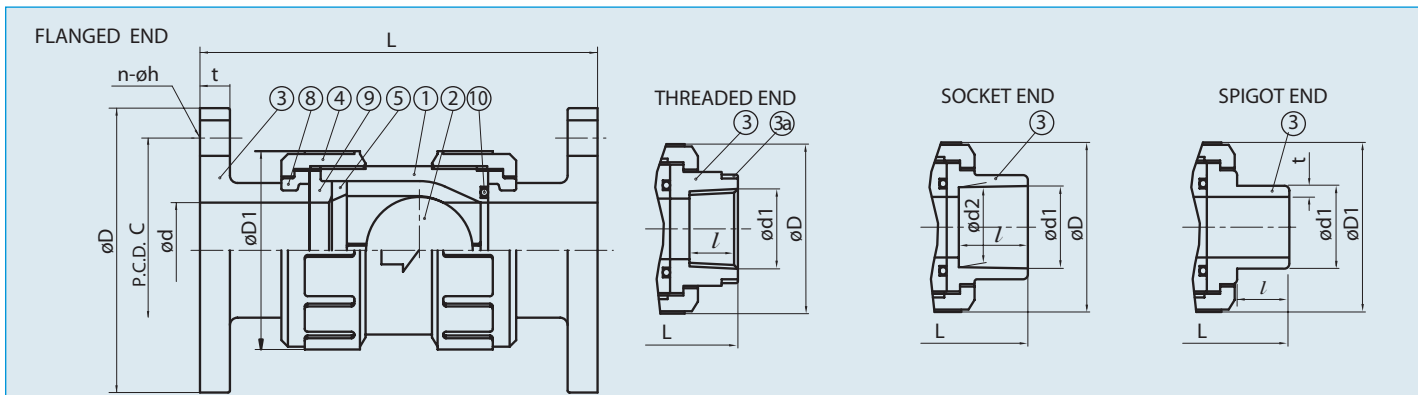

Dimensions (Sizes 1/2" - 2")

NOMINAL SIZE	FLANGED		THREADED				SOCKET												SPIGOT(BUTT END)									
							PVC, CPVC			PP, PVDF (DIN)			PP, PVDF (IPS)			PP, PVDF												
	INCHES	mm	D	C	n	h	L	t	d1	l	L	d	D1	d1	d2	l	L	d1	l	L	d1	l	t	t	L			
1/2	15	3.50	2.38	4	0.62	5.12	0.47	1/2-14NPT	0.59	3.39	0.59	1.89	0.848	0.836	0.688	3.43	0.768	0.760	0.57	3.19	0.83	0.87	3.31	0.787	0.728	0.098	0.075	4.00
3/4	20	3.88	2.75	4	0.62	6.10	0.55	3/4-14NPT	0.67	4.06	0.79	2.36	1.058	1.046	0.719	3.86	0.965	0.957	0.63	3.70	1.03	1.00	4.43	0.984	0.866	0.106	0.075	4.35
1	25	4.25	3.12	4	0.62	6.50	0.55	1-11 1/2NPT	0.79	4.45	0.98	2.76	1.325	1.310	0.875	4.37	1.240	1.232	0.71	4.13	1.30	1.13	4.35	1.260	0.866	0.118	0.094	4.75
1 1/4	32	-	-	-	-	-	-	1 1/4-11 1/2NPT	0.87	5.00	1.22	3.78	1.670	1.655	0.938	4.92	-	-	-	-	-	-	-	-	-	-	-	-
1 1/2	40	5.00	3.88	4	0.62	7.56	0.63	1 1/2-11 1/2NPT	0.98	5.94	1.57	3.78	1.912	1.894	1.094	5.94	1.947	1.937	0.93	5.62	1.89	1.37	5.57	1.969	1.260	0.181	0.118	5.75
2	50	6.00	4.75	4	0.75	8.43	0.63	2-11 1/2NPT	1.10	6.97	2.01	4.17	2.387	2.369	1.156	6.77	2.461	2.445	1.08	6.69	2.36	1.50	6.49	2.480	1.417	0.228	0.118	6.50

Ball Check

Single Union



Parts List – Single Union (Sizes 3" – 4")

PARTS			
NO.	DESCRIPTION	PCS.	MATERIAL
1	Body	1	PVC, CPVC, PP, PVDF
2	Ball	1	PVC, CPVC, PP, PVDF
3	End Connector	1	PVC, CPVC, PP, PVDF
4	Union Nut	1	PVC, CPVC, PP, PVDF
5	Stop Ring (A)	1	PVC, CPVC, PP, PVDF
6	Flange		PVC, CPVC, PVDF
7	Stub		PVC, CPVC, PVDF
8	Stop Ring (B)*	1	PVDF
9	Seat	1	EPDM, FKM, PTFE

* Used for flanged end

Dimensions (Sizes 3" – 4")

NOMINAL SIZE	INCHES	mm	FLANGED									SOCKET									THREADED			SPIGOT (BUTT END)					
			ANSI Class 150									PVC, CPVC			PP, PVDF (DIN)			PP, PVDF (IPS)			PP, PVDF								
												ASTM SCH40			DIN 16962						DIN 3442								
			D	C	n	h	L	t1	t2	d1	d2	l	L	d1	d2	l	L	d1	l	L	d1	l	L	d1	l	t	t	L	
3	80	3.07	5.98	7.50	6.00	4	0.75	12.20	0.71	0.87	3.516	3.492	1.875	9.57	3.512	3.498	1.40	8.46	3.480	1.874	9.55	3-8 NPT	1.38	8.74	3.543	1.496	0.323	0.169	11.67
4	100	3.94	8.27	9.00	7.50	8	0.75	15.63	0.71	0.87	4.518	4.491	2.000	12.20	4.293	4.278	1.63	11.46	4.480	2.252	12.60	4-8 NPT	1.77	12.09	4.331	1.752	0.394	0.209	13.93

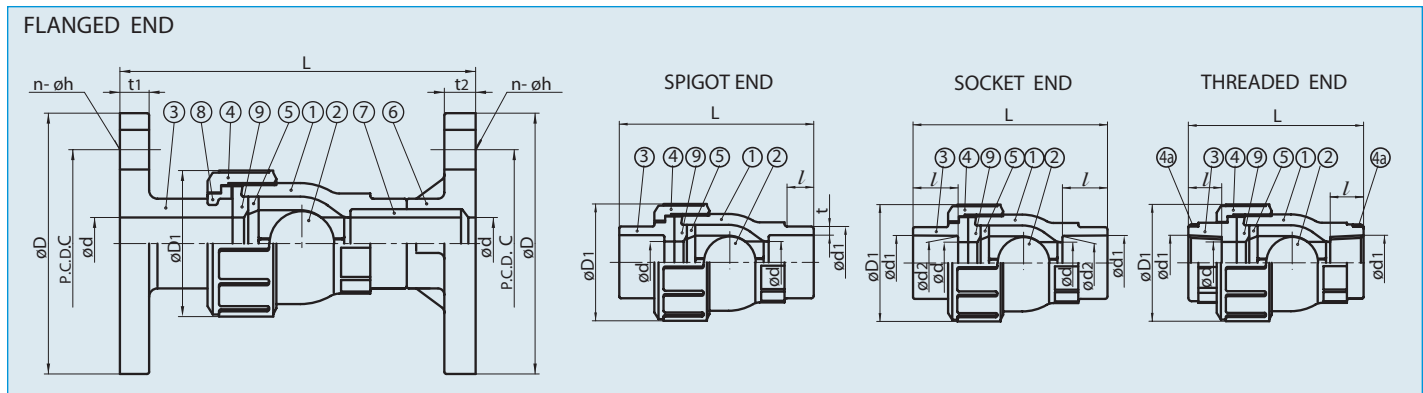

True Union, Single Union, and Foot Valve Weight (POUNDS)

NOMINAL SIZE		SOCKET	FLANGED
INCHES	mm		
1/2	15	0.22	0.66
3/4	20	0.44	1.10
1	25	0.66	1.54
1 1/2	40	1.54	2.20
2	50	2.20	3.31
3	80	6.17	9.92
4	100	14.99	24.25

Cv Values

NOMINAL SIZE		Cv
INCHES	mm	
1/2	15	6.5
3/4	20	17
1	25	25
1 1/2	40	86
2	50	130
3	80	280
4	100	500

Sample Specification – (BALL CHECK VALVES)

All ball check valves and foot valves shall be of solid thermoplastic construction, and shall be designed with an elastomeric uniseat/seal for tight shut-off under pressure. Sizes 1/2" through 2" shall be of True Union design, while 3" & 4" shall be Single Union design. The same seal shall function as both the ball seat and the union seal. PVC shall conform to ASTM D1784 Cell Classification 12454-A, CPVC shall conform to ASTM D1784 Cell Classification 23567-A, PP shall conform to ASTM D4101 Cell Classification PP0210B67272 and PVDF shall conform to ASTM D3222 Cell Classification Type II. Ball Check valves and foot valves sizes 1/2" – 2" shall be rated 150 psi at 70 degrees F, 3" and 4" rated 100 psi at 70 degrees F, as manufactured by Asahi/America, Inc.

Ball Check

Foot Valve Option

Parts List Foot Valve (Sizes 1/2" – 2")

PARTS			
NO.	DESCRIPTION	PCS.	MATERIAL
1	Body	1	PVC
2	Ball	1	PVC
3	End Connector	1	PVC
4	Union Nut	1	PVC
5	Stop Ring (A)	1	PVC
8	Stop Ring (B)*	1	PVDF
9	Seat	1	EPDM, FKM, PTFE
10	O-Ring	2	EPDM, FKM, PTFE
11	Screen	1	PVC

* Used for flanged end

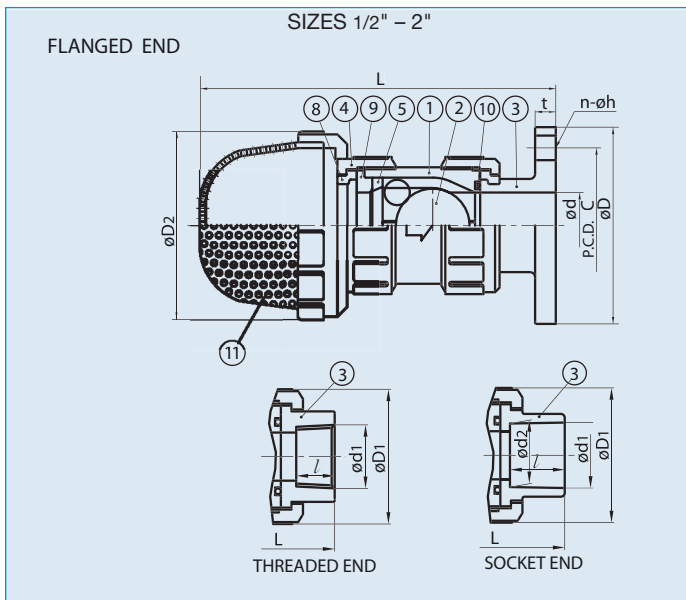

Parts List Foot Valve (Sizes 3" – 4")

PARTS			
NO.	DESCRIPTION	PCS.	MATERIAL
1	Body	1	PVC
2	Ball	1	PVC
3	End Connector	1	PVC
4	Union Nut	1	PVC
5	Stop Ring (A)	1	PVC
6	Flange*	1	PVC
7	Stub*	1	PVC
9	Seat	1	EPDM, FKM, PTFE
11	Screen	1	PVC

* Used for flanged end

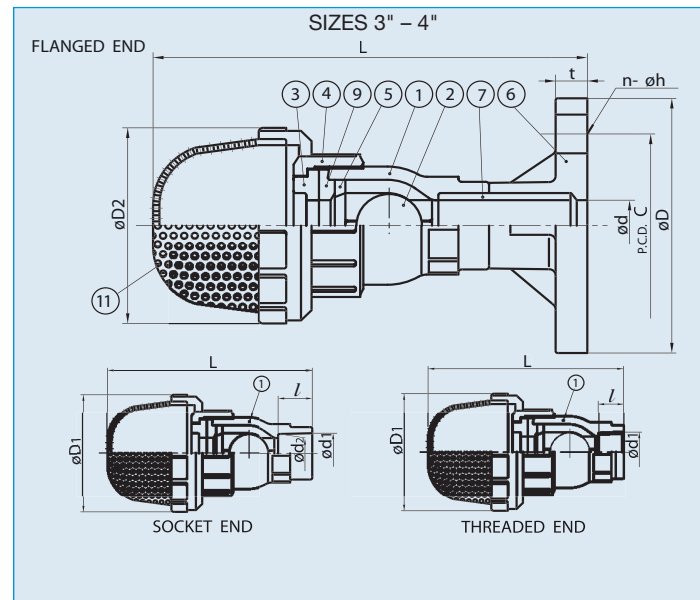

Pressure vs. Temperature – BALL CHECK AND FOOT VALVES (PSI, WATER, NON-SHOCK)

NOMINAL SIZE		PVC		CPVC			PP			PVDF				
		30° F	120° F	30° F	121° F	141° F	176° F	-5° F	86° F	141° F	-30° F	141° F	176° F	196° F
INCHES	mm													
1/2 - 2	15-50	150	150	120	90	60	150	90	60	150	125	110	90	
3 - 4	80-100	100	100	90	60	45	75	60	45	100	90	60	45	

Foot Valve Wt. (LBS) Dimensions (1/2"–4")

NOMINAL SIZE		SOCKET	FLANGED	NOMINAL SIZE		SOC.	THR'D	FLG.	
INCHES	mm			INCHES	mm				D2
1/2	15	0.22	0.66	1/2	15	2.36	4.73	4.69	5.40
3/4	20	0.44	0.88	3/4	20	2.76	5.32	5.52	6.40
1	25	0.66	1.32	1	25	3.78	6.24	6.32	6.90
1 1/2	40	1.54	3.31	1 1/2	40	5.24	8.33	8.33	8.50
2	50	2.20	3.31	2	50	5.24	8.97	9.17	10.50
3	80	7.71	11.02	3	80	11.80	12.60	11.80	14.60
4	100	15.43	23.14	4	100	18.25	18.25	18.25	20.25

Caution

- Never remove valve from pipeline under pressure.
- Always wear protective gloves and goggles.